

FIBERGLASS TANKS

Above Ground Storage



FIBERGLASS TANKS

Above Ground Storage

TABLE OF CONTENTS

1	INTRODUCTION	3
2	GENERAL DESCRIPTION	3
3	INTERNATIONAL STANDARDS	4
4	DESIGN AND MANUFACTURING	4
	4.1 Manufacturing	4
	4.1.1 End Cap	4
	4.1.2 Tank Shell Fabrication	5
	4.1.3 Assembly	6
5	PRODUCT RANGE	7
	5.1 Horizontal Tanks	7
	5.2 Vertical Tanks	8
6	MAINTENANCE FREE	9
7	STRENGTH, DURABILITY AND ECONOMICS	9
8	QUALITY PROCEDURES	10
	8.1 Incoming Raw Materials	10
	8.2 Components Production Checks	10
	8.2.1 Tank Shell	10
	8.2.2 End Cap	10
	8.2.3 Complete Tank	10
9	HANDLING	11
10	INSTALLATION	11

1. INTRODUCTION

Future Pipe Industries (FPI) is the world's leader in design and manufacturing of composite fiberglass pipe systems and storage tanks. FPI offers bespoke pipe system solutions for the water, O&G and industrial sectors. Through its pioneering use of fiberglass, service excellence and product technologies, FPI is a pioneer in the conversion of world pipe demand into fiberglass. With the largest portfolio of high-temperature, high-pressure, anti-corrosive, composite large-diameter fiberglass pipes in the world, FPI offers a comprehensive range of products and services including; engineering, project management, technical support and in-house, on-site training.



Fiberglass storage tanks mean lower total cost and greater dependability over the life of your storage system free of maintenance cost. The most important difference between FPI Fiberglass tanks and metallic tanks is that Fiberglass tanks do not corrode.

Corrosion-caused replacement costs are eliminated, as are periodic corrosion testing procedures, and the additional expense and concern over leakage problems.

2. GENERAL DESCRIPTION

Future Pipe Industries (FPI) produces a wide range of high-quality, multi-purpose storage tanks using proven FIBERSTRONG® technology. Flexible & corrosion - resistant, FPI's tanks are manufactured from a thermo setting resin and fiberglass reinforcement and can be used for the storage of petroleum products, water and a wide range of chemicals. When storage is required for highly corrosive material, FPI's dedicated design team can provide bespoke solutions utilizing specific vinyl ester resins in the inner liner of the tank or throughout the tank wall. FIBERSTRONG® tanks are ideal for underground (back filled), and aboveground (horizontal or vertical) applications and come in a standard range up to 4,000 mm in diameter, offering a nominal storage capacity from 1,000 liters up to 200,000 liters (44,000 IG). Customized design and non-standard configurations are considered on a case by case basis.

Aboveground Fiberglass tanks, are manufactured by Future Pipe Industries by joining different components made using different manufacturing techniques such as filament winding and hand lay-up with chemical resistant liners resulting in maintenance free product suitable for gravity storage of a wide range of liquids.

3. INTERNATIONAL STANDARDS

Future Pipe Industries fabricates its fiberglass tanks in accordance with the requirements of recognized international standards such as:

- American Water Works Association: AWWA D120.
- American Society of American Engineers: ASME RTP-1
- British Standard : BS 4994

4. DESIGN AND MANUFACTURING

The future pipe group has gained years of experience of production and installation of fiberglass tanks under various conditions. This experience with wide range of fiberglass tanks along with the relevant standards has enabled future pipe group to develop and qualify a fit for purpose product line. The water tank consists of a tank shell, end caps, manway and different connectors and accessories (Refer drawing).

The tanks are manufactured by the filament winding process using glass reinforcements in combination with resin. Usually unsaturated polyester resins are used since they give good performance for potable water applications, aggregates may be added. The filament winding process of the cylindrical shells allows the use of continuous glass fiber reinforcements in the circumferential direction and chopped glass roving to provide sufficient strength in axial direction. A very compressed laminate is created that maximizes the contribution from the three basic raw materials. In various parts, the glass reinforcements are applied in the form of continuous filaments, chopped strand and woven roving for high hoop strength and axial reinforcement. Isophthalic or Vinylester resin is used in the liner and Isophthalic polyester resin in the structure. For special industrial applications, full Vinylester tanks can be supplied. Glass reinforcements are either "C", "E" or Advantex "ECR" glass.

The tanks shell will be equipped with all requested connectors and accessories before the end cap will be added to the main body by using the lamination method.

4.1 Manufacturing

4.1.1 End Cap

The end caps are fabricated on a revolving mold by means of chopped glass and spray resin operation. The inner layer of the cap shall consist of surface mat C glass layer, impregnated with resin. Chopping roving are then fed through a gun which automatically chops the glass and sprays both glass and resin on the mold. Woven roving and aggregates may be used in the structural wall when required. The material is rolled out as it is deposited on the mold. A final resin rich layer covers the cap outer surface.



4.1.2 Tank Shell Fabrication

The shell is manufactured by using the continuous filament winding process. Tank shell fabrication is broken down into the following manufacturing procedures:

A. Machine Description - The **FIBERSTRONG®** continuous filament winding machine as used by Future Pipe Industries (FPI) is a representative of the modern state-of-the-art filament winding technology for use in the manufacturing of glass fiber (composite) pipes.



Simply, this manufacturing machine consists of a mandrel composed of a helical wound continuous steel band and supported in a cylindrical shape by beams. As the beams turn, friction pulls the steel band around and roller bearings allow the band to move in longitudinal pipe direction so that the entire mandrel moves continuously in a spiral path towards the exit assembly. As the mandrel rotates and the pipe moves slowly but continuously toward the end of the assembly station, all composite materials are metered onto it in precise amounts. Electronic sensors provide continuous production parameters feedback so that the various feeding systems apply the right amount of material. This will ensure that the amount of material needed to build the liner and the structure is uniformly applied throughout the manufacturing stage and it assures a constant glass fraction. After the pipe has been formed on the mandrel it is cured and later cut to the required length.

B. Liner Application - First, mold-release film is applied, followed by a C glass veil impregnated with resin. The rest of the liner is made of chopped glass reinforcements and resin.

C. Structural Layer Application - Once the liner materials are applied, structural reinforcements, i.e. Chopped and filament wound glass roving and aggregate are deposited simultaneously along with resin and aggregates.

D. Outer Layer - The tank shell has a resin rich outer layer. For water application the tank must be coated by an opaque paint to prevent the growth of algae and bacteria caused by sun light exposure.

4.1.3 Assembly

The end caps, manway, lifting fittings and cradles are assembled to the tank shell according to the guidelines of ASME RTP-1

A. End Cap Assembly - The finished end caps are fitted over the shell ends and bonded using a mixture of resin, chopped strand mat and woven roving.

B. Man-way/ Nozzle Assembly - A hole is cut at the proper location to match the required diameter. The man-way/ nozzle is placed in the hole, supported and bonded to the outside of the shell using woven roving and chopped strand mat, all wetted with resin and rolled onto the shell and man-way.

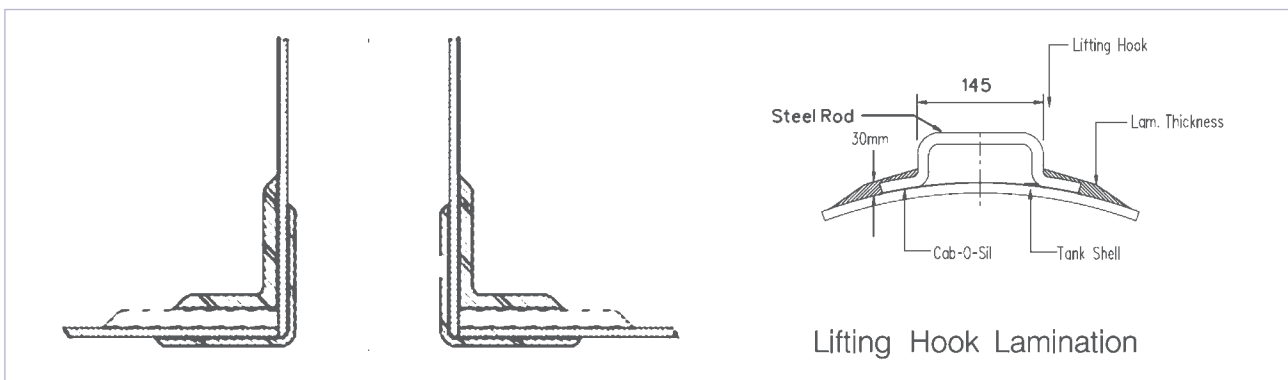

Lifting Fitting Assembly - Steel lifting lugs are provided on each tank to facilitate handling.

C. Horizontal tanks are fitted with cradles, upon which it will depend for support.

D. Vertical tank have flat bottoms and are placed on concrete slabs

5. PRODUCT RANGE

FPI's proven **FIBERSTRONG®** technology and continuous winding process allows the manufacture of GRP aboveground water storage tanks with individual diameter and volume, based on customer's request. However, we also offer a standard product range of GRP tanks for various purposes that can be installed above and underground. **FIBERSTRONG®** tanks for aboveground (horizontal or vertical) applications and come in a standard range up to 4,000 mm in diameter, offering a storage capacity of up to 200,000 liters (44,000 IG). Larger capacities are available upon request.

5.1 Horizontal Tanks

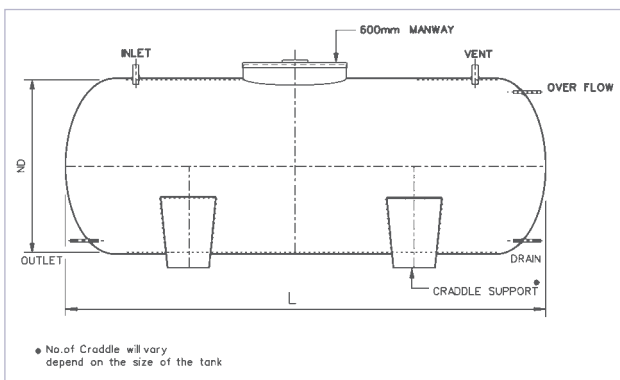

Notes:

- 1) All dimensions are in mm unless otherwise noted
- 2) All nozzle flange drilling to be advised by client.
- 3) Design Pressure: Atmospheric
- 4) For larger tanks, Two Man-ways may be used.
- 5) Number of cradle will be increased as per the tank length.
- 6) Product range of tank will be vary as per the requirement of client.

ND (Tank Nominal Diameter)	Nominal Capacity	L (length)
	Liter	
1000	1000	1616
1200	2000	2090
1200	3000	2950
1200	4000	3800
1200	5000	4870
1200	10000	9510
1600	5000	2960
1600	10000	5570
1600	15000	8190
2000	10000	3720
2000	15000	5390
2000	20000	7070
2000	25000	8740
2400	15000	3910
2400	20000	5070
2400	25000	6230
2400	30000	7390
2800	30000	5750
2800	40000	7450
2800	50000	9110
2800	75000	13380
2800	100000	17500
3500	80000	9450
3500	90000	10550
3500	100000	11600
4000	100000	9180
4000	140000	11930
4000	160000	13530
4000	180000	15130
4000	200000	16730

5.2 Vertical Tanks

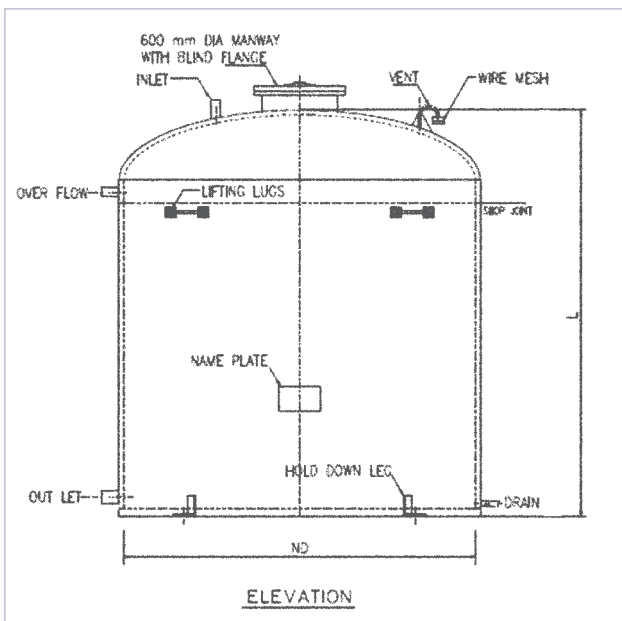
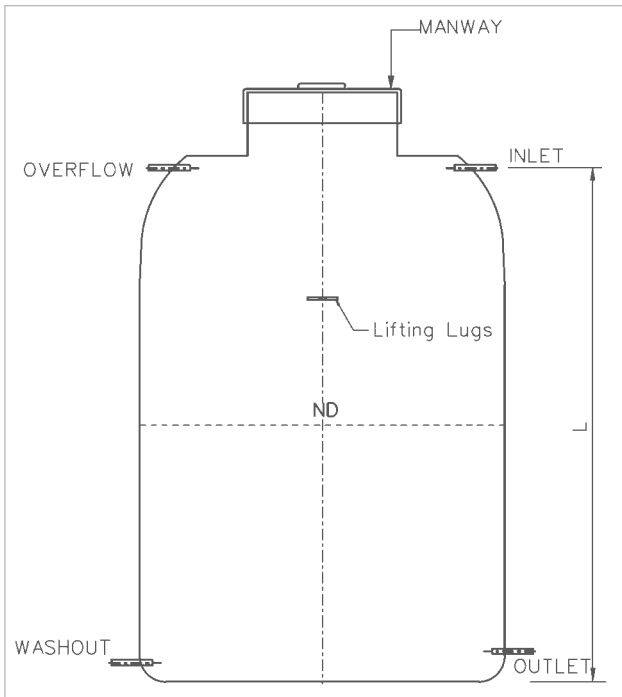

ND (Tank Nominal Diameter)	Nominal Capacity	L (length)
	Liter	
1200	1000	1310
1200	2000	2210
1200	3000	3110
1200	4000	4010
1200	5000	4910
1600	5000	3040
1600	10000	5640
1600	12000	6640
2000	6000	2520
2000	7000	2820
2000	8000	3170
2000	9000	3520
2000	10000	3920
2000	16000	5770
2000	18000	6420
2000	20000	7120
2400	10000	2920
2400	16000	4270
2400	20000	5170
2400	26000	6520
2400	28000	6970
2400	30000	7520
2800	25000	4950
2800	40000	7450
2800	45000	8250
3500	40000	5225
3500	50000	6325
3500	60000	7325
4000	60000	5940
4000	80000	7590
4000	100000	9240

6. MAINTENANCE FREE

Fiberglass tanks are not susceptible to corrosion, they are maintenance free. A Fiberglass storage tank will last the life of most facilities without corrosion caused leaks or failures. Corrosion caused replacement costs are eliminated, as are periodic corrosion testing procedures, and the additional expense and concern over environmental problems due to leakage.



7. STRENGTH, DURABILITY AND ECONOMICS

Properly installed fiberglass tanks are strong enough to withstand occasional and sustained loads like winds, earth quake etc. Fiberglass aboveground tanks offer incomparable performance benefits combined with quick, easy installation. The performance of a fiberglass storage tank means substantial savings over the life of the installation, compared to a steel tank. Fiberglass tanks mean no corrosion, no maintenance and no additional expense for tank replacement.

8. QUALITY PROCEDURES

Future Pipe Industries operates a quality management system in accordance with the requirements of BS EN ISO 9001. Under this quality system, inspection and testing are carried out at all critical stages of manufacture.

8.1 Incoming Raw Materials

Prior to their use in the manufacture, raw materials are checked against Future Pipe strict written standards.

8.2 Components Production Checks

8.2.1 Tank Shell

As soon as the shell is manufactured, the following checks are carried out:

Type of test	Each shell	Once each shift	Standard reference
Wall thickness	X		FPI / ASTM D 3567
Visual inspection	X		FPI / ASTM D 2563
Internal diameter		X*	FPI / ASTM D 3567
Length	X		FPI / ASTM D 3567
Barcol hardness	X		FPI / ASTM D 2583
Loss on ignition (LOI)		X**	FPI / ASTM D 2584

* Measured as the mandrel diameter at the start-up of the production run.

** A lot is defined as 360 m or 30 pipes.

8.2.2 End Cap

Each end cap is inspected for the following:

Type of test	Standard reference
Wall thickness	FPI / ASTM D 3567
Visual inspection	FPI / ASTM D 2563
Barcol hardness	FPI / ASTM D 2583

8.2.3 Complete Tank

Every tank, when complete with accessories is tested for the following:

Type of test	Standard reference
Filling with water for 24 hours	FPI

Records of all testing will be maintained by Future Pipe.

9. HANDLING

Each tank will be packaged for safe handling with identified locations for lifting either by Forklift type loaders or placement of belts for lifting by cranes where often tanks are provided with lifting lugs. Tanks must be securely lashed to truck beds and when necessary proper permits must be obtained tanks extending outside the trailer bed.



Future Pipe Industries will provide detailed instructions on a project basis for safe handling of tanks.

Precautions

Do not roll or drop tanks. Only use lifting equipment to move tanks. Capacity of lifting equipment must be checked before moving tanks. Set tanks on smooth ground, free of rocks and foreign objects.

10. INSTALLATION

Fiberglass tanks are easy to install, light weight - approximately quarter the weight of steel tanks - of equivalent storage capacity. Lighter, less expensive equipment is needed for installation. Also lower installation costs due to the requirements of smaller foundations and structural supports.



