

# WAVISTRONG™

Underground Pipe System  
Installation Manual







---

Underground Pipe System  
Installation Manual

## Preface

- All the contents and data published in this brochure have been licensed to **Future Pipe Industries**. No photocopies or microfilms of this brochure are allowed without the prior written authorization from the said licensee.
- **Future Pipe Industries** reserves the right to change the data published data in this brochure without any prior notification. Published data can be changed by the said company for specific project requirements.
- For any technical query, please consult the **Future Pipe Industries**.

## Table of Content

|   | Page |
|---|------|
| 1- Introduction.....  | 2    |
| 2- Handling .....   | 3    |
| 3- Trench Specifications .....                              | 7    |
| 4- Backfilling and Installation Selection.....              | 9    |
| 5- Joints .....   | 16   |
| 6- Special Requirements.....                                | 20   |
| 7- Pipe Deflection .....                                    | 24   |
| 8- Field Testing .....                                      | 27   |
| 9- Pipeline Commissioning.....                              | 30   |
| 10- Air in Pipelines, Air Valves and Surge Control .....    | 31   |
| 11- Repair and Replacement of Pipe.....                     | 33   |
| 12- Tapping WAVISTRONG (H2O) Water Series Water Mains ..... | 33   |
| <b>Appendix I</b> .....                                     | 34   |
| Approximate Weight of Pipe and Joint                        |      |
| <b>Appendix II</b> .....                                    | 35   |
| Design Consideration for Pipelines Anchoring                |      |
| <b>Appendix III</b> .....                                   | 38   |
| List of References  |      |

## 1.0 Introduction

This manual deals with the handling, laying and testing of Wavistrong™ (H2O) Water Series pipes. Pipe diameter ranges from 100 mm up to 1200 mm with a pressure class of 10 bar and stiffness classes of 5000 or 10000 N/m<sup>2</sup>. Pipes are solid wall type (non-ribbed). Table 1 shows Wavistrong™ (H2O) Water Series pipe standard lengths.

| Nominal Pipe Diameter (mm) | Standard Pipe Length (m) |
|----------------------------|--------------------------|
| 80                         | 5                        |
| 100 - 300                  | 5                        |
| 350 - 600                  | 5                        |
| 700 - 800                  | 5                        |
| 900 and above              | 5                        |

Table 1-Standard Pipe Length

This manual should be carefully read by the Contractor responsible for laying the pipes, as well as by the design Engineer. This information should be considered only as a guide. The Engineers or others involved in pipeline design or installation should establish for themselves the procedure suited to the site conditions. Sound engineering practices should always be followed.

Our site service representatives are at the disposal of the Contractor / end user in order to advise on the handling and installation of the pipes. We also have the capability for executing the pipe system installation (excluding any civil and mechanical work) and have a dedicated team for such services. Please contact our engineers for further details.

### 1.1 Responsibilities of the Wavistrong™ (H2O) Water Series Manufacturer Site Supervisors

The responsibilities of our site supervisors are:

- Periodic visits to the job site throughout the duration of pipe installation to advise the contractor on the proper and applicable handling, storage, bedding, laying, jointing, backfilling and site testing procedures necessary to achieve a satisfactory Wavistrong™ (H2O) Water Series pipe installation. These procedures are detailed in this manual.
- It is the responsibility of the Contractor to make available the Wavistrong™ (H2O) Water Series pipe installation manual to his installation crew, and to ensure that they are familiar with, and understand the procedures described therein.
- It is the responsibility of the Contractor to strictly follow and implement the installation procedures published in this installation manual, as well as any additional advice given by our site representative.
- The Wavistrong™ (H2O) Water Series manufacturer shall not be liable for any failures related to installation arising from failure of the Contractor to follow and implement our written installation instructions and any additional advice or recommendation made by our field representative.

## 2.0 Handling

### 2.1 Receiving

Generally pipes will be handed over to the Contractor or his representative at the factory or at the job site as agreed upon in the Contractor's purchase order. In the case of an Ex-works delivery, the pipes and fittings shall be loaded on the Contractor's trucks by the factory loading staff. If the loading staff considers the transport unsuitable, they will advise the contractor or his representative accordingly. Inspection is thoroughly made by the factory loading staff of the goods being loaded. Nevertheless the Contractor or his representative should make their own inspection of the goods during dispatch.

The Contractor should make the following inspection at the time of the reception of the goods:

- a- Each item should be inspected with care upon its arrival.
- b- Total quantity of pipes, couplings, rubber rings, fittings, lubricant, etc... should be carefully checked against the delivery notes.
- c- Any damaged or missing item must be pointed out to the dispatcher or driver and noted on the delivery note.

Materials that have been damaged during transportation should be isolated and stored separately on site, until the material is checked by our site representative and repaired or replaced.

**Note 1:** Damaged material must not be used before it is repaired.

### 2.2 Unloading Pipes

Unloading at the job site must be carried out carefully under the control and responsibility of the Contractor. Care should be taken to avoid impact with any solid object (i.e. other pipes, ground stones, truck side etc.).

#### 2.2.1 Unloading by Hand

Unloading by hand with two men is only allowed for small diameter pipes, not exceeding 60 kg.

**Note 2:** See Appendix 1 for list of pipe and coupling weights.

### 2.2.2 Mechanical Unloading

Mechanical unloading is required for pipes heavier than 60 kg. Flexible slings or straps should be used combined with a mobile crane. When unloading is done with a mobile crane, care must be taken that the pipes do not slide off the slings. Therefore it is recommended to use two slings or nylon lifting straps to hold and lift the pipes. Steel cables must not be used for lifting or handling Wavistrong™ (H2O) Water Series pipes. Wavistrong™ (H2O) Water Series pipes can also be lifted with one sling or strap balanced in the middle with the aid of a guide rope.

**Caution:** Hooks must not be used at the pipe ends to lift the pipes, nor should the pipe be lifted by passing a rope or sling through the pipe.

## 2.3 Unloading Couplings

Couplings shall be unloaded with care. They must not be thrown off the truck on the ground. In general, couplings are strapped and bundled in the factory and can be off loaded like the pipes.

## 2.4 Storing Rubber Gaskets on Site

Rubber gaskets are delivered in closed bags from the factory and must be stored in a cool shaded area, protected from direct sunlight, until they are ready for use.

## 2.5 Storing Wavistrong™ (H2O) Water Series Pipes on Site

### 2.5.1 Distribution along the Trench

It is preferable to unload Wavistrong™ (H2O) Water Series pipes alongside the trench directly from the truck. If the trench is opened, string out the pipes on the opposite side to the excavated earth. Allow sufficient space between pipes and the trench for excavator, cranes, etc. Avoid placing the pipes where they can be damaged by traffic or blasting operations. If possible, store pipes on soft level ground (e.g. sand), timber bearers, or sand bags.

**Caution:** Pipes must not be stored on rocks.

### 2.5.2 Storing in Stock Piles

Care must be taken that the storage surface is leveled, firm, and clear of rocks or solid objects that might damage the pipes. Store the pipes in separate stockpiles according to their class and nominal diameter. If it is necessary to stack pipes, it is best to stack on flat timber supports at maximum 3 meters spacing. The maximum stack height is approximately 2 meters. This height is limited for safety purposes and to avoid excessive loads on the pipe during storage.



Wooden wedges, which are used in order to prevent the pipe stack from sliding, should be placed on both sides of the stack on the timber bearers, as shown in figure 1.

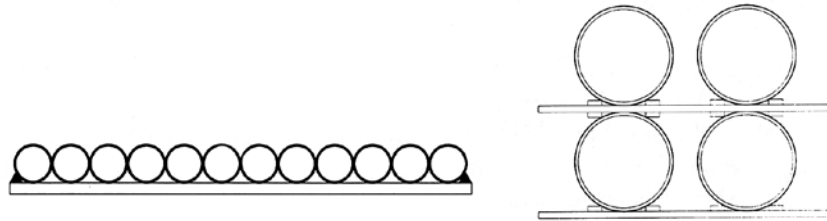

Figure 1: Pipe storage

## 2.6 Handling of Nested Pipes

Pipes may be delivered nested (i.e. one or more small pipes inside a larger pipe). Special handling procedures must be followed when handling and de-nesting such pipe loads.

When handling nested pipes, never use a single sling or strap. Nested pipes must always be lifted using at least two straps or slings. A spreader bar will help to insure that the load is lifted uniformly. Mobile lifting equipment should move slowly when handling nested pipes and all such movements should be kept to a minimum to insure the safety of site personnel. The Contractor should insure that the crane operator realizes that the smaller pipes inside the larger nested pipes may slip out and fall during movement. All necessary precautions should be taken.

De-nesting a load is easily accomplished by inserting a forklift fork into a padded boom. The forklift lifting capacity should be appropriate enough to handle the weight and length of the pipes being de-nested. Proper padding is essential. Rubber, several wraps of corrugated cardboard sheets, or a PVC or PE pipe slipped over the boom are all suitable options to avoid damaging the inside of the nested pipes.

The Forklift operator should lift the innermost pipe above the pipe around it sufficiently so the pipes do not touch each other when the inner pipe is being pulled out.

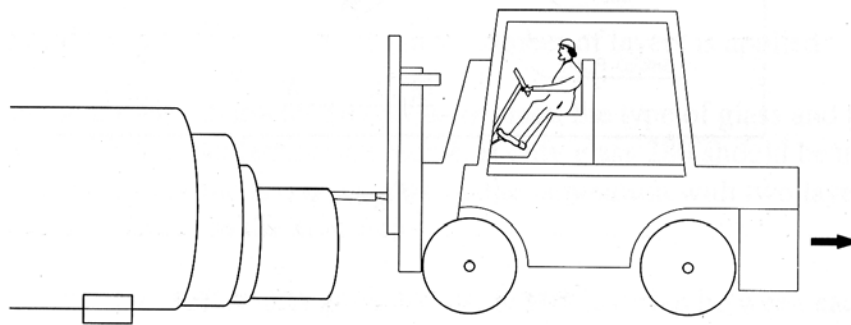

Figure 2: Pipes de-nesting

## 2.7 Lowering the Pipe into the Trench

Hand loading should be executed by at least two men. It is recommended that the weight carried by one man should not exceed 30 kg. Pipes weighing up to 175 kg can be lowered by means of two ropes. The ropes must be anchored to stakes as indicated in figure 3.



Figure 3: Lowering with ropes

Mechanical lowering is used for larger diameter pipes, especially when combined with pipe assembly in the trench. Two straps or slings can be used from an excavator boom if no separate lifting equipment is available.

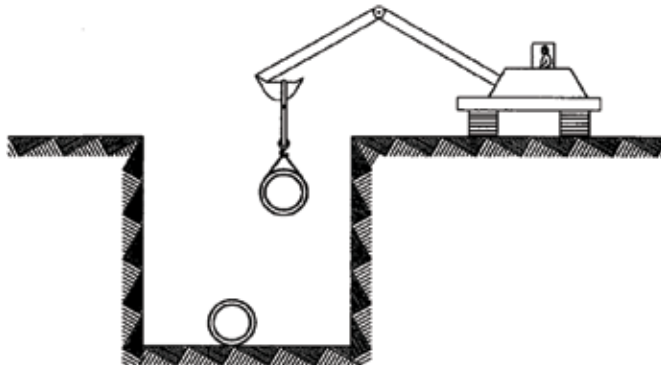

Figure 4: Mechanical lowering with excavator

### 3.0 Trench Specifications

#### 3.1 The Trench

The trench excavation should not be too far ahead of the pipe-laying team to ensure a better control of the trench and for safety reasons. The excavated soil should be placed on one side of the trench leaving the other side, clear for equipment and pipe handling. If the trench consists of various layers of soils, these should be placed separately in order to use the stone-free granular material for backfill.

#### 3.2 Minimum Trench Width

The trench width must be maintained within certain limits. A very wide trench will increase the volume of backfill material required, and compaction labor and effort. A very narrow trench will render laying, handling and joining of pipes, as well as compaction of side backfill difficult. The minimum recommended trench width is given in figure 5.

**Notes 3:**

1. In poor native soil conditions and depending on pipe stiffness and burial depth, a wide trench (up to 4 X DN) might be required. See section 4.7 for additional details.
2. The distance between the pipe and the trench wall should be at least 10cm wider than the width of the equipment used for compaction of the backfill material.

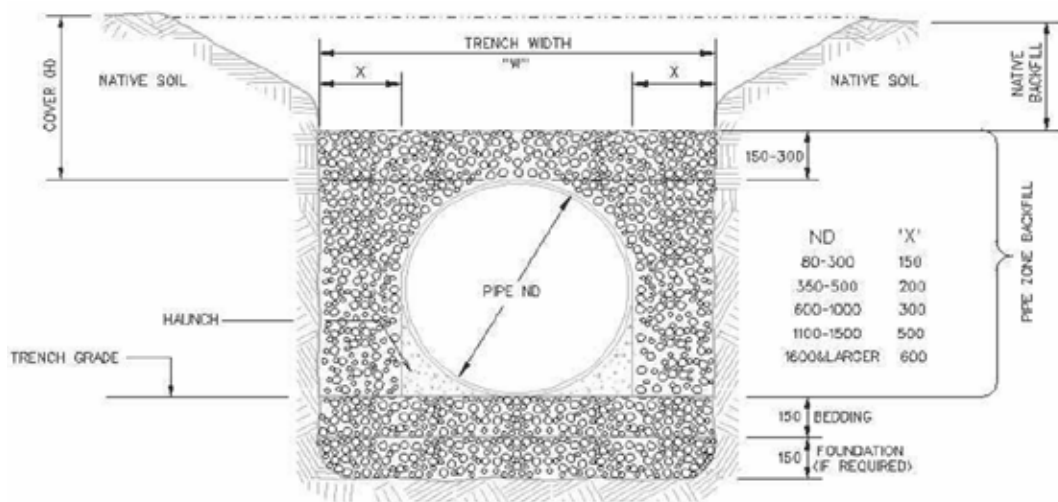

Figure 5: Minimum Trench Width

### 3.3 Parallel Pipes Installed in the same Trench

Where two, or more, Wavistrong™ (H2O) Water Series pipes are installed in parallel in the same trench, the following minimum distance should be maintained in order to allow for sufficient room to place and compact the backfill material under the pipe haunches, for all the pipes in the trench. The distance between the pipes should be at least 10 cm wider than the width of the equipment used for compaction of the backfill material.

Where Wavistrong™ (H2O) Water Series pipes of the same or different diameters are installed in the same trench, a minimum spacing equal to  $(ND \text{ pipe } a + ND \text{ pipe } b)/4$ , but not smaller than 300mm, is required.

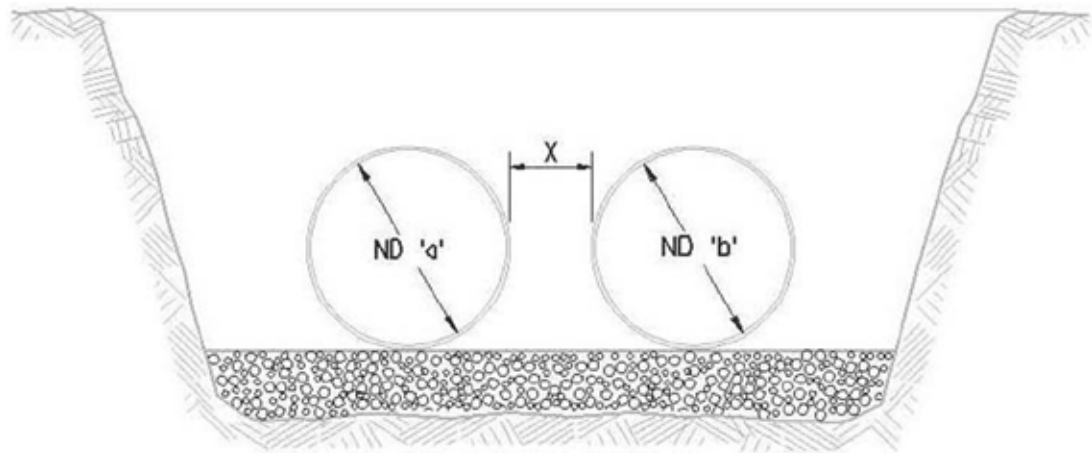

Figure 6: Pipes in the same trench

### 3.4 Trench Depth

#### 3.4.1 Minimum Trench Depth

Generally the cover depth of pipe is specified by the design Engineer. When there is no traffic load over the pipe, the minimum burial depth is 0.6m. In the presence of traffic loads, a minimum cover above the pipes shall always be maintained as follows for all stiffness classes.

| Load Type      | Traffic (wheel Load) |        | Minimum Burial Depth |
|----------------|----------------------|--------|----------------------|
|                | Kn                   | Lbs    | Meters               |
| AASHTO H20 (C) | 72                   | 16,000 | 1                    |
| BS 153 HA (C)  | 90                   | 20,000 | 1.5                  |
| ATV LKW 12 (C) | 40                   | 9,000  | 1                    |
| ATV SLW 30 (C) | 50                   | 11,000 | 1                    |
| ATV SLW 60 (C) | 100                  | 22,000 | 1.5                  |

Table 2 - Minimum Cover Depth

**High Water Table**

In case of high ground water table, a minimum cover depth equal to 0.75 times the pipe diameter of granular soil (minimum dry density of 1900 Kg/m<sup>3</sup>) must be provided to prevent Wavistrong™ (H<sub>2</sub>O) Water Series pipes from floating. Always insure that this minimum cover is available before turning off dewatering systems.

**3.4.2 Maximum Cover Height**

The maximum cover height depends on the type of installation, backfill material and its compaction, as well as native soil conditions.

**4.0 Backfilling and Installation Selection**

The installation type and choice of Pipe Embedment Zone material is normally specified by the design Engineer based on the specified pipe stiffness class (SN), maximum burial depth, vacuum requirements, and native soil conditions.

**SN** = Specific tangential initial stiffness; N/m<sup>2</sup> = E.I/D<sup>3</sup>

**4.1 Acceptable Pipe Foundation and Pipe Embedment Zone Backfill Materials**

Most coarse-grained soils are generally acceptable as backfill materials for the foundation and pipe Embedment Zone. The following materials may be used if compacted to the required degree.

| Soil Category         | Symbol (as ASTM 2487)                      |
|-----------------------|--|
| Crushed Rock / Gravel | GW, GP, GW-GC, GW-GM, GP-GC, GP-GM, GM, GC |
| Sand                  | SW, SP, SW-SC, SW-SM, SP-SC, SP-SM, SM, SC |

Table 3 - Acceptable Backfill Material

The maximum particle size is as follows:

| Pipe Diameter              | Maximum particle Size |
|----------------------------|-----------------------|
| DN less than 600 mm        | 13 mm                 |
| DN between 600 and 1200 mm | 19 mm                 |

Table 4 - Maximum Particle Size

If the native soil meets the specifications in tables 3 and 4 above, the same soil may be used in the Pipe Embedment Zone.

## 4.2 Migration

When backfill materials such as gravel and crushed rocks are placed in a trench adjacent to finer native material, the finer material may migrate into the coarser material under the flow pressure force of the ground water table. Migration can also occur when selected sand is used as backfill in a trench where the native soil is coarser.

Significant hydraulic gradients may arise in the pipeline trench during construction, when water levels are controlled by various pumping or well-pointing methods.

Gradients may also arise after construction, when permeable under drain or when the open graded embedment materials act as a "french" drain under high ground water levels. Migration can result in significant loss of pipe support and increasing pipe deflections that may eventually exceed the design limits of the Wavistrong™ (H2O) Water Series pipe.

The gradation and relative size of the embedment and adjacent native soils must be compatible in order to minimize migration. In general, where the ground water table is above the foundation or bedding level and when the native soil is finer than the backfill, avoid using open graded materials such as crushed rocks and gravel unless a geotextile filter fabric is used to line the trench bottom and sides.

The following gradation criteria may be used to restrict the migration of finer material into a coarser material under a hydraulic gradient:

- $D_{15} / d_{85} < 5$  where  $D_{15}$  is the sieve opening size passing 15 percent by weight of the coarser material and  $d_{85}$  is the sieve opening size passing 85 percent by weight of the finer material.
- $D_{50} / d_{50} < 25$  where  $D_{50}$  is the sieve opening size passing 50 percent by weight of the coarser material and  $d_{50}$  is the sieve opening size passing 50 percent by weight of the finer material.  
(This criteria doesn't apply if the coarser material is well graded  
{See ASTM D2487})

### 4.3 Determination of Native Soil Properties

In order to choose the appropriate installation type and to identify the allowed burial depth limits, it is necessary to determine native soil properties. Proper soil investigation along the pipeline route is an engineering practice that should be executed by the Contractor in case no soil data is provided by the end user. When no soil data is available, borehole samples should be taken along the pipeline route at intervals of not more than 500 meters. If the native soil properties and appearance are not consistent over this distance, shorter intervals for sampling should be adopted. Soil samples must be taken from a depth that provides the necessary information at the pipe embedment zone level of the pipeline.

#### Important soil properties

- Physical characteristics, appearance, and gradation
- Water table location
- Blow counts (N) per ASTM D1586 (Standard Penetration Test)

### 4.5 Classification of Native Soils

Native soils can be classified into five main groups and two sub groups, cohesive and granular:

|  | 1     | 2          | 3                | 4      | 5          |
|--|-------|------------|------------------|--------|------------|
| <b>Blow counts (N)<br/>(ASTM D 1586)</b> | >30   | 16-30      | 8-15             | 4-7    | 1-3        |
| <b>Cohesive Soils</b>                    | Hard  | Very Stiff | Stiff            | Medium | Very Soft  |
| <b>Granular Soils</b>                    | Dense | Compact    | Slightly Compact | Loose  | Very Loose |

Table 5 - Native Soil Groups

### 4.6 Standard Installation

Installation selection, unless otherwise specified by the end user, shall be based on the native soil properties, pipe stiffness class (SN), and burial depths. Figures 7A to 7D illustrate the four installation types. Table 6 specify the maximum burial depth with and without traffic loads respectively for pipe with a stiffness class of SN 5000 and SN 10000 in a native soil of group 1 to 5.

#### • Installation type I

Full gravel/crushed stones surround, compacted to 70% Relative Density

#### • Installation type II

Full sand, with less than 12% fines, surround compacted to 90% SPD

Installation Type

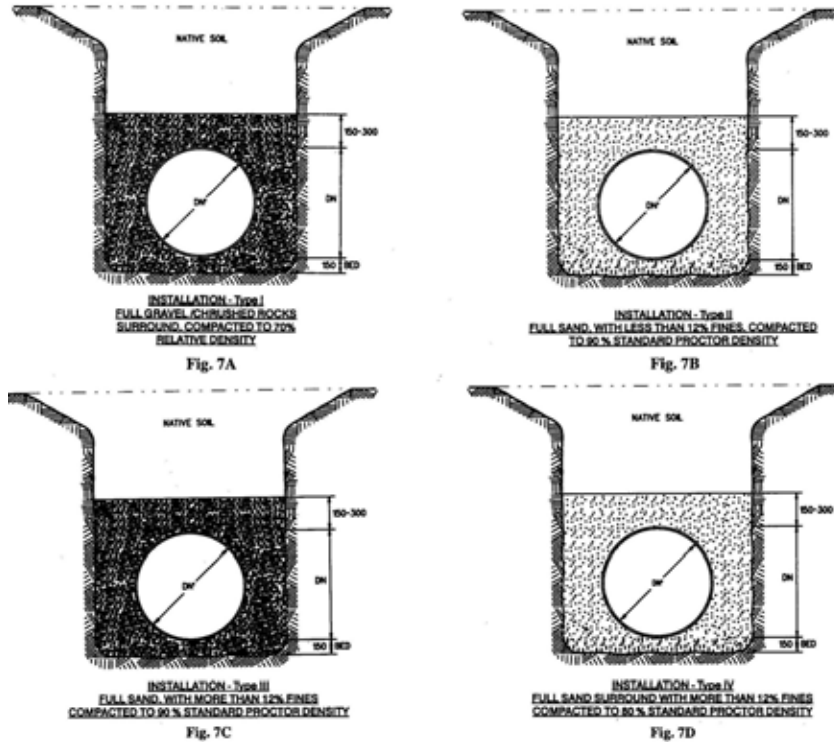

| Installation Type       | Native Soil Group |    |   |   |     |
|-------------------------|-------------------|----|---|---|-----|
|                         | 1                 | 2  | 3 | 4 | 5   |
| Large Diameter DN > 250 |                   |    |   |   |     |
| Pipe Stiffness 5,000    |                   |    |   |   |     |
| 1                       | 15                | 10 | 8 | 6 | 2   |
| 2                       | 10                | 5  | 4 | 3 | NR  |
| Small Diameter DN < 300 |                   |    |   |   |     |
| Pipe Stiffness 10,000   |                   |    |   |   |     |
| 1                       | 8                 | 7  | 6 | 5 | 2.5 |
| 2                       | 6                 | 5  | 4 | 3 | 1   |

Table 6 - Standard Trench Maximum Burial Depth (meters) With Traffic Load

**4.6 Alternative Installations**

For alternative installation methods, please refer to manufacturer for recommendations.



## 4.7 Pipe Bedding and Foundation

To ensure a firm support for Wavistrong™ (H2O) Water Series pipe, proper bedding must be provided under the pipe. During trench excavation, a pipe bedding thickness of at least 150 mm must be provided. In case of very poor native soils (silt, clay or mud) additional 150 mm thick foundation layer must be provided below the bedding. Selected backfill material should be placed at the foundation and bedding levels and thoroughly compacted by plate vibrators or by hand tamping. Wetting of sand bedding/foundation material prior to compaction will improve and facilitate the achievement of the degree of compaction required.

Pipe laying should always take place in dry trenches. It is not acceptable to lay pipes in flooded trenches. The Contractor should provide the necessary dewatering equipments to enable installation to proceed in a dry trench. Dewatering equipment should be removed and pumps turned off only after completion of backfilling the Pipe Embedment Zone, and sufficient backfill has been provided to prevent pipes from floating if the normal ground water level is above the pipe invert.

Prior to lowering the pipe into the trench small holes should be dug under each joint location so the pipe does not rest on the joints. The bedding material should provide firm and continuous support over the entire length of the pipe, excluding the joint areas. The Contractor should lower the pipe into position after checking the proper levels and alignment of the pipeline.

## 4.8 Pipe Embedment Zone

The selected backfill material should be evenly placed and properly compacted on both sides of the pipe. Appropriate hand or mechanical tamping shall be carried out by the Contractor to achieve the specified degree of compaction required by the selected installation type. During the first one or two lifts, special care should be taken to place and to compact the backfill material under the pipe haunches. The best way to achieve this compaction is to do it manually with the mean of a wooden board.

**This is one of the most important installation steps and should be executed with care.**

**Failure to place and to compact the backfill material under the pipe haunches may cause ovalization, localized loads and over deflection of the pipes.**

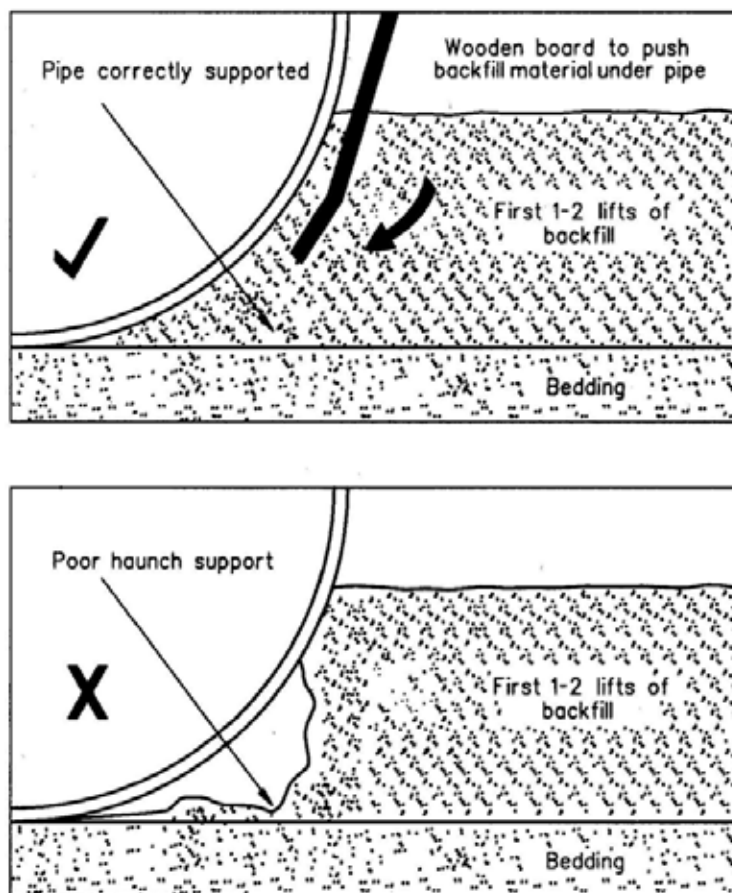

Figure 8: Backfilling pipe haunches

Pipes jointed in the trenches should not be left for long periods without backfilling as some joints may rupture as a result of the daily expansion and contraction of the pipes due to ambient temperature fluctuation. However, if the pipes are sufficiently restrained to prevent movement, the joints may be left exposed for an easy visual inspection during the field hydro test. These joints must be backfilled immediately after the test to avoid damages.

The Contractor should note that the compaction of clean and mixed sand is best achieved when the material is at its optimum moisture content. While the wetting of sand is recommended prior to compaction, trench flooding should be avoided to prevent pipes from floating.

Following the first two layers where the backfill has been sufficiently placed, compaction should proceed from the sides of the trench towards the pipe. The Pipe Embedment Zone backfill should proceed in 150 to 300 mm lifts depending on backfill type (see section 4.1). The Pipe Embedment Zone backfilling and compaction should continue until the backfill reaches at least 15 cm above the pipe crown. For pipes larger than 1000mm in diameter, backfilling the Pipe Embedment Zone should continue to 300 mm above the pipe crown.

After completion of backfilling in the Pipe Embedment Zone, native material excavated from the trench may be used to complete the backfilling to final grade. No compaction is required in these final backfilling layers except where specified by the Engineer, or in the case of traffic or other high external loads over the pipe where settlement of the native backfill is to be avoided.

**Caution:** Sand layers of more than 300 mm cannot be compacted properly and may result in loss or reduced support for the pipes. The best compaction results are achieved with wet sand near its optimum moisture content. But Flooding of the trench must be avoided as pipe floatation may occur. A minimum of 1 pipe diameter of granular backfill is normally required to prevent Wavistrong™ (H2O) Water Series pipes from floating.

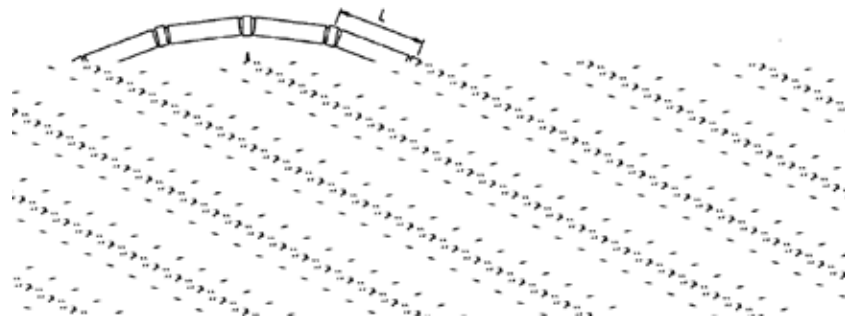

Figure 9: Double Bell Coupler Joint Angular deflection, offset and radius of curvature

## 5.0 Joints

### 5.1 Double Bell Coupling

#### 5.1.1 Joint Angular Deflection

Double bell coupling joints, used to join Wavistrong™ (H2O) Water Series pipes, allows for a certain angular deflection. The maximum allowed angular deflection, distributed equally on both sides of the joint, and the resulting **Offset** and the radius of curvature (**R**) are given with respect to the pipe nominal diameter and section length, in table 7.

| DN (mm)     | Joint Deflection (degree) | Offset (mm) |         |         | Radius (meters) |         |         |
|-------------|---------------------------|-------------|---------|---------|-----------------|---------|---------|
|             |                           | L = 1 m     | L = 3 m | L = 5 m | L = 1 m         | L = 3 m | L = 5 m |
| < 500       | 3                         | 52          | 157     | 262     | 19              | 57      | 95      |
| 500 to 800  | 2                         | 35          | 105     | 175     | 29              | 86      | 143     |
| 900 to 1200 | 1                         | 17          | 52      | 87      | 57              | 172     | 286     |

Table 7: Allowable Double Bell Coupler joint angular deflection

**Note 4:** The angular deflection can occur in the horizontal as well as in the vertical plane. It is recommended that above limits not to be reached during installation.

#### 5.1.2 Joint Lubricant

For lubricant, use only a vegetable based soft soap, available from the Wavistrong™ (H2O) Water Series manufacturer. In dusty conditions lubricate generously the coupling only. The recommended amount of joint lubricant required is shown below.

| DN (mm)     | Amount of lubricant required per joint (kg) |
|-------------|---|
| 80 - 300    | 0.05  |
| 350 - 500   | 0.1   |
| 600 - 800   | 0.12  |
| 900 - 1000  | 0.2   |
| 1100 - 1200 | 0.25  |

Table 8 - Lubricant Consumption

**Caution:** Never use petroleum-product grease or automotive oils to lubricate the joint, as they will damage the rubber rings.

### 5.1.3 Preparation of the REKA Wavistrong™ (H2O) Water Series Coupling (Double Bell Coupler)

In order to avoid damage, the sealing rubber ring must be fitted into the REKA FIBERSTRONG coupling just before the laying starts.

- For large sizes lay the coupling horizontally for better control and safety.
- Clean the groove in the coupler and the rubber ring before inserting it.
- Insert the rubber ring into the groove, leaving uniform loops extending out of the groove. There should be one loop for every 500 mm of ring circumference. Do not lubricate the rubber or the groove at this stage.
- With uniform pressure, push all the loops simultaneously into the groove.
- Make sure that the compression in the ring is uniformly distributed all around the circumference.

### 5.1.4 Mounting the Coupling on the Pipe

This operation can be carried out either inside or outside the trench. In the latter case it is recommended to lower the pipe with the free end towards the laid portion of the line. Clean coupling and pipe ends with a firm brush and inspect them thoroughly. Lubricate the pipe end and the coupling rubber ring by means of a dry clean piece of cloth or a sponge.

For small diameter pipes (DN<350 mm) the coupling can be mounted by hand or with a crow bar. Use a timber block to protect the coupling and force the coupling into the correct position that is indicated by the home line on the pipe spigot.

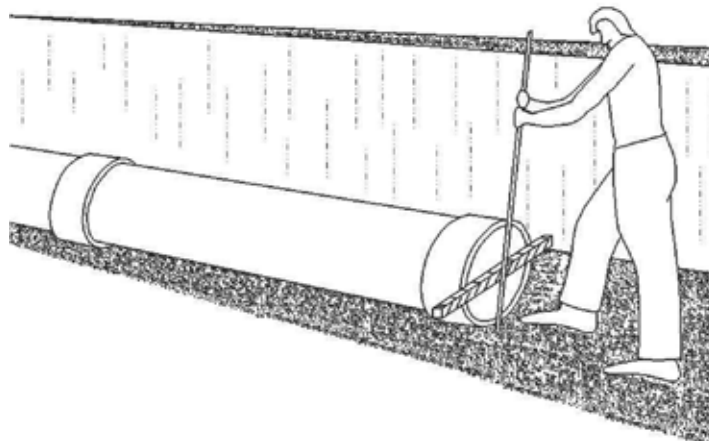

Figure 10: Mounting the coupling for DN  $\square$  350 mm

For pipes with diameters above 350 mm, a come-along type puller is used. This apparatus is fixed to the outside of the pipe by friction.

**Caution:** Under no circumstance should brute force be applied to mount the coupling. The pipes and couplings are dimensioned within tolerances that allow jointing to be carried out without using excessive effort.

### 5.1.5 Inserting the Pipe in the Coupling

Joints should be made inside the trench following the procedures shown in figures 11 and 12. A steel strap with rubber lining must be fixed on the installed pipe at the home line in order to stop the insertion of the pipe in the coupler at the pipe home line. Alternatively a wooden spacer may be used inside the couplings to maintain the correct spacing.

All spacers must be removed immediately after jointing the pipes. Spacers may damage air valves and other valves fitted in the system if they are not removed before the hydrostatic test. Before insertion, the two pipes should be perfectly aligned and leveled to avoid any damage to the rubber rings.

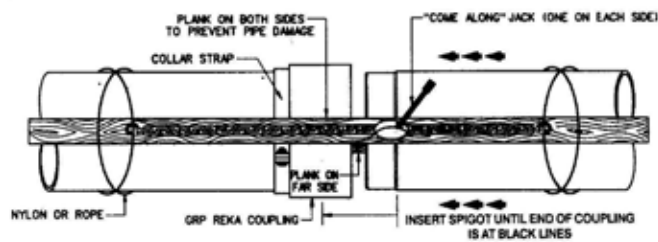

Figure 11: Pipe Jointing using a "come along" jack

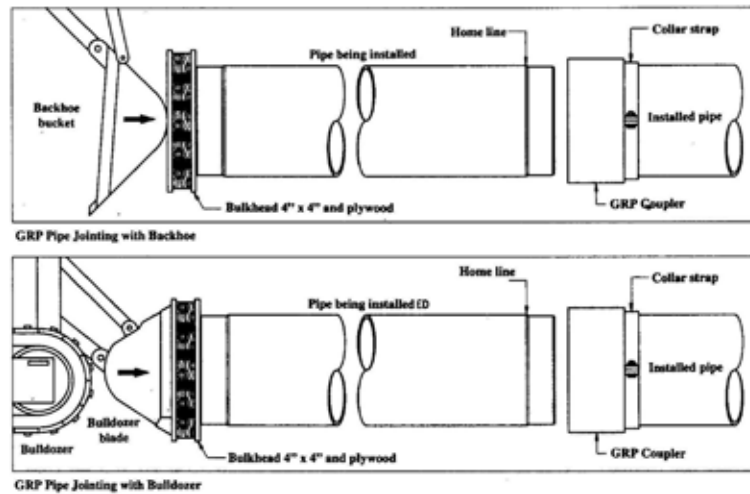

Figure 12: Pipe Jointing using construction plants

Working with mounting equipment, although very efficient, should not be carried out by unskilled laborers. Risks of damaging or dislodging a rubber ring should not be disregarded. It is essential to push the coupling to the home line and not beyond, otherwise the pipes in the coupling will touch each other and will consequently not allow for any expansion or deflection inside the joint. Only skilled operators should attempt to use the boom of an excavator to push either coupling or pipe, as the direction of the applied force is not under control and might damage the pipes and/or the coupling. No steel tools should come into direct contact with the edges of the pipe or its external surface. Pipe edges should be protected with a timber.

## 5.2 Lamination Joints

This joint is made from glass fiber reinforcement embedded in polyester resin. The length and thickness of the joint depends on the diameter and the pressure.

This type of joints requires special working conditions and should be performed only by skilled workers.

Always consult the pipe manufacturer before performing lamination joints.

## 5.3 Flanged Joints

Flanged pipes and fittings can be provided for use inside valve chambers. Contact our engineers for Wavistrong™ (H2O) Water Series flange thickness before ordering flange bolts as they are thicker than steel flanges.

## 6. Special Requirements

### 6.1 Standard Short Pipe Lengths

Standard short Wavistrong™ (H2O) Water Series pipe lengths are required in various situations, such as:

- Outside rigid structures (i.e. water reservoirs, pumping station, thrust blocks, valve chambers, manholes, etc.)
- To connect the pipes to line fitting such as bends or tees inside thrust blocks.

Standard short lengths of pipes shall be planned ahead by the contractor. The recommended length (L) of standard short pipe is 1.5 X DN with a maximum of 2000 mm and a minimum of 500 mm

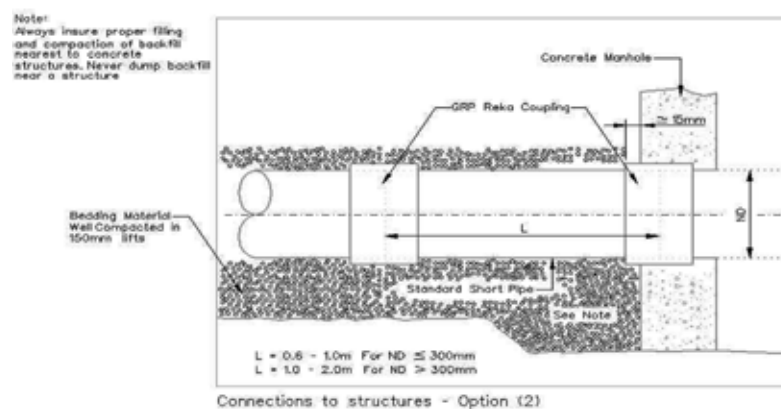
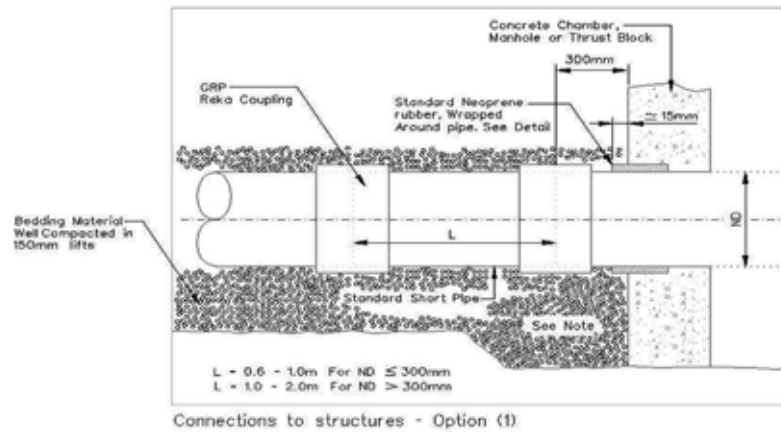

Figure 13: Standard Short Pipe



## 6.2 Pipeline Closures

For a closure in a line it is required to order a special short pipe from the factory with double width calibration. The Contractor should clearly indicate in his order that a short pipe closure is required. In closure pipes, the length of the machining is equal at least to the width of the Wavistrong™ (H2O) Water Series REKA coupling plus 30 mm. In case of export jobs or where the site is very far from the factory, cutting and machining of closure pipes must be carried out on site. We will provide supplementary instructions for export projects.

Before ordering a closure pipe, the Contractor should measure accurately the gap between the two ends of the line. The length of the pipe to be fitted must be 32 mm less than the measured length to allow a gap of 16 mm between the jointed ends in both couplings. Mark the home line on the machined ends if necessary and lubricate them abundantly. The assembly of the short length pipe is made as indicated in the figure 14 below.

**Caution:** When pulling the couplings over the insertion piece it is necessary to pull the second rubber ring smoothly over the chamfer of the pipe to avoid damaging it. For that purpose, use approved lubricants abundantly. To locate a fitting exactly, it is recommended to place it at the required position, to assemble the first pipe in full length, and then to make a closure as indicated above.

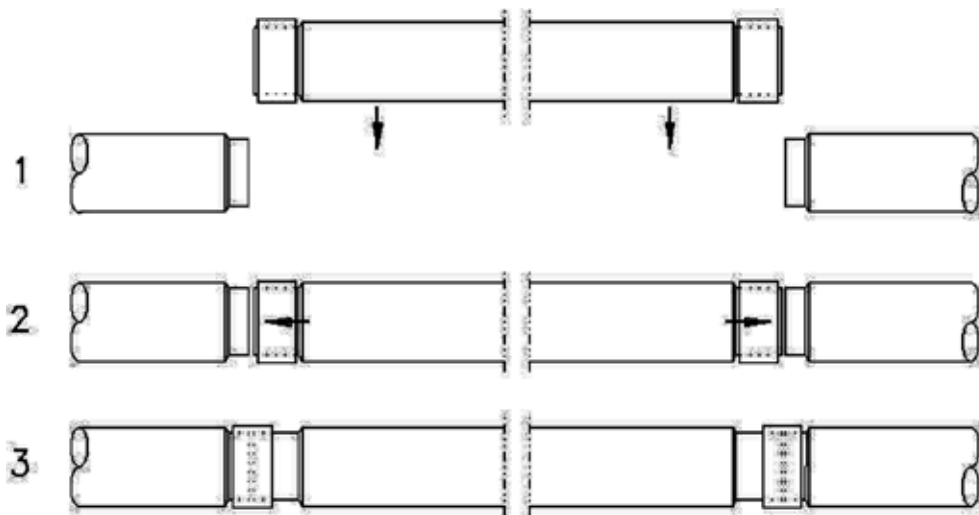

Figure 14: Pipeline closure

### 6.3 Thrust Blocks and Anchoring

Thrust blocks can be used in pipeline systems with non restrained joints such as the double bell coupling wherever thrust loads are expected, such as at:

- Changes of direction (bends, Tees, Wyes)
- Cross section changes (reducers)
- Valves and hydrants
- Dead ends

The thrust blocks can be dimensioned and designed according to the expected thrust load as well as native soil properties. Thrust block spaces must be foreseen in the design and trench excavations. At vertical bends, the line or the bend must be anchored by thrust blocks or other means to resist outward thrusts. Thrust blocks must be cast against undisturbed trench walls (native soil) and must **completely encase the FIBERSTRONG fitting** (except at the joint area). The maximum allowable displacement of fittings is 0.5% of the diameter, or 6 mm; whichever is less. The outlet part of the encased Wavistrong™ (H2O) Water Series fitting in the concrete block shall be rubber wrapped as shown in figure 15. See appendix II for additional information about thrust blocks.

**Note 5:** Gravity lines up to 1 bar pressure do not require thrust blocks.

**Caution:** Always provide a standard short pipe length outside thrust blocks (see section 6.1) to protect the pipeline from differential settlement.

Nozzle connections are not necessarily to be concrete encased. Nozzles are tee branches meeting all the following criteria:

1. Nozzle diameter  $\square$  300mm
2. Header diameter  $\square$  3 times nozzle diameter
3. If the nozzle is not concentric and/or not perpendicular to the header pipe axis, the nozzle diameter shall be considered to be the longest cord distance on the header pipe wall at the nozzle/pipe intersection.

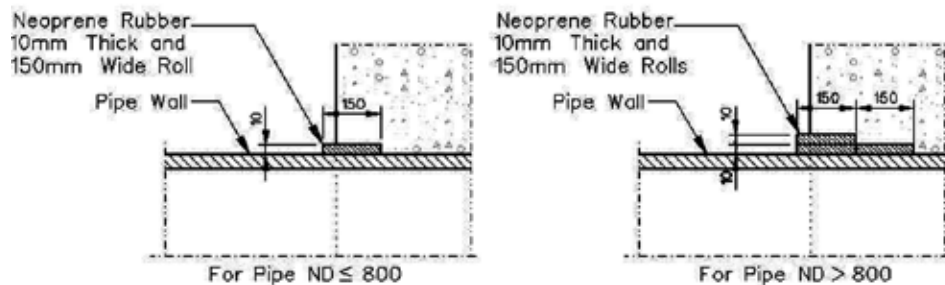

Figure 15: Rubber wrapping

## 6.4 Concrete Encasement

Pouring concrete around the pipe results in uplifting forces that can damage the pipe and/or joint. To avoid such movement, the pipe should be anchored downward by straps hooked to a rigid base. The straps should be of flat material of minimum 25 mm width. The distance between straps should not exceed 4 meters with a minimum of one strap per section length. Straps should not be over-tightened.

## 6.5 Fittings for Valve Chambers

One of the advantages of Wavistrong™ (H2O) Water Series pipe systems is customized fittings. Using a Wavistrong™ (H2O) Water Series pipe system greatly simplifies the valve chamber design and eliminates unnecessary flanged joints as shown in figure 16. Valves must be sufficiently anchored to take the thrust force.

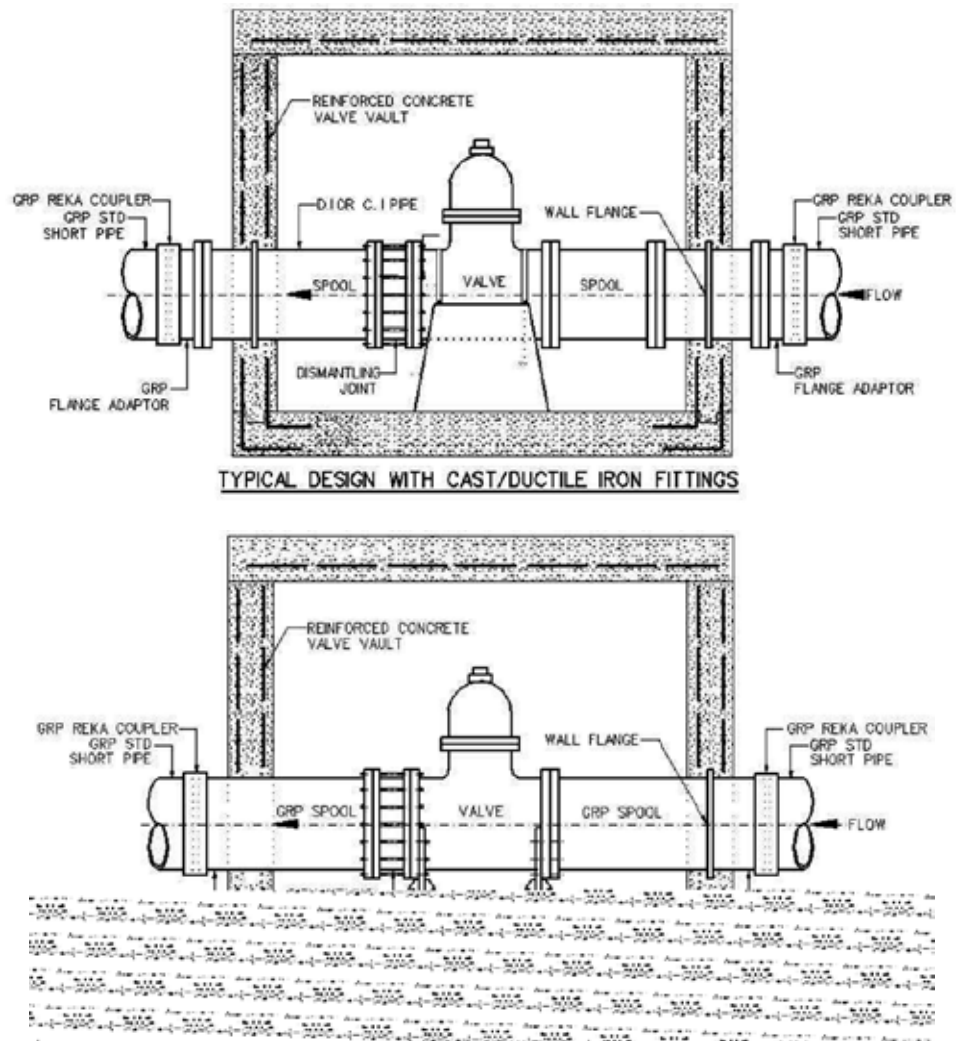

Figure 16: Valve Chamber

## 7.0 Pipe Deflection

The deflection of Wavistrong™ (H2O) Water Series pipe depends on the pipe diameter, pipe medium, and native soil classification. Pipe deflection is defined as the percentage reduction in vertical diameter after installation, as shown below in figure 17.

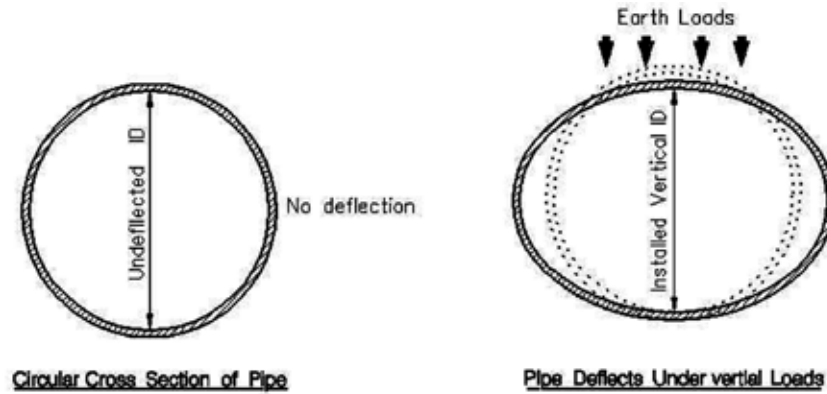

Figure 17: Pipe deflection

$$\% \text{ Deflection} = 100 \times \frac{\text{Actual undeformed pipe ID} - \text{Installed vertical ID}}{\text{Actual undeformed pipe ID}}$$

To insure that the long-term deflection does not exceed the maximum allowable limit, the preliminary & initial deflection of the pipe must be monitored and controlled on site by the Contractor. Maintaining the deflection within the allowable limits is achieved by proper selection of pipe stiffness, installation methods related to the native soil conditions, and maximum burial depth.

Measuring pipe deflections is easy and is the best way for the contractor to check if the installation was executed properly.

### **Wavistrong™ (H2O) Water Series pipes deflection is measured in the following manner:**

For pipe sizes 800 mm and larger, where human entry inside the pipes is possible, the installed vertical pipe ID can be measured by means of a manual micrometer at 3 to 4 m intervals. An electronic deflectometer can be used to measure the deflection of the pipes of diameter within the range of 15 to 800 mm. A probe with censored arms is pulled through the line, recording the pipe ID on a data logger kept outside the line. The results are then presented on a computer-generated report.

A wooden disc (Pig ball), with an outside diameter equal to the maximum acceptable deflected pipe ID, may be pulled through the pipes. If the pig passes freely, it means that the pipe deflection has not exceeded the limit set by the pig OD. Please check the figure 18 for a typical configuration of a wooden Pig.

**Note 6:** It is important that pipe deflection measurements are done at the same time of pipe laying operations and not after. This will allow for early detection of any installation deficiencies and allow corrective action to be taken quickly in order to reduce the time and expenses necessary to rectify defective installations.

|                                   | Deflection (% of Pipe Diameter) in a native soil of group |     |     |     |     |
|-----------------------------------|---|-----|-----|-----|-----|
|                                   | 1   | 2   | 3   | 4   | 5   |
| <b>Large Diameter DN &gt; 250</b> |   |     |     |     |     |
| Initial                           | 4   | 3.5 | 3   | 2.5 | 2   |
| Long Term                         | 5   | 5   | 5   | 5   | 5   |
| <b>Small Diameter DN &lt; 300</b> |   |     |     |     |     |
| Initial                           | 1.8   | 1.8 | 1.5 | 1.1 | 1.1 |
| Long Term                         | 3   | 3   | 3   | 3   | 3   |

Table 9 - Maximum Allowable Deflection

## 7.1 Preliminary Deflection

This measurement should be taken when backfill reaches 30 cm above pipe crown. At this stage the measured deflection should be slightly negative, but not exceeding -2%. A negative deflection means the pipe vertical ID has increased because of the compaction forces/stresses coming from the side backfill.

A positive deflection at this stage it indicates inadequate compaction in the Pipe Embedment Zone, hence improvement in the quality of installation and compaction is required. In such cases, it is advisable to remove the backfill to about 1/3 of the pipe ID from the pipe invert level and to re-compact the backfill in stages up to the top of the pipe zone, with special care to the compaction of the pipe haunches backfill area. After this rectification, the preliminary deflection should be measured again.

## 7.2 Initial Deflection

This measurement should be done immediately after backfilling reaches the final grade and after all temporary sheeting has been withdrawn and all de-watering systems have been turned off for two days. The initial deflection limits are set to account for creep and soil consolidation with time (determined by the deflection lag factor).

If the initial deflection exceeds the allowable limits up to 8% of the pipe diameter, the contractor should re-excavate the trench (by hand from 0.3 m above pipe crown), remove the Pipe Embedment Zone backfill and start re-backfilling the pipe, paying attention to the pipe haunches and backfilling in appropriate lifts to reach the required compaction. If the deflection slightly exceeds the allowable limits, the deflection may be monitored over the following 6 months period with monthly deflection measurements. If deflections at the end of the 6 months do not exceed the allowable long-term deflection limit, the pipeline section may be considered as accepted.

Any recently installed pipe exhibiting deflections equal or greater than 9% (7% for pipes SN 10,000) must be replaced. Such pipe must not be re-installed nor incorporated in any permanent works on site.

## 7.3 Final Deflection

This measurement should be done at least 6 months after the initial test is done. The maximum deflection at this stage should not exceed the limits specified in table 9.

## 8.0 Field Testing

### 8.1 Line Hydrostatic Testing

Prior to the hydrostatic test, several points must be checked in order to avoid failures.

- While the contractor tends to test long sections to increase his efficiency, the length of the test section should be short enough to allow an easy detection of any possible leak. It is also very difficult to fill a very long line without the risk of air entrapment.
- The backfilling must have been carried out properly and reached a level that would restrain the pipes to avoid movements during testing. The joints may be left exposed for visual inspection. The thrust blocks, which are part of the pressure test section, should be of permanent constructions and concrete should be poured at least 7 days before testing.
- Check whether all testing apparatus are available and operational.
- The opened ends of a line must be sealed temporarily with GRE or steel/Cast iron end-caps. GRE testing end-caps can be purchased from the manufacturer with the pipes and fittings. All the end-caps should have an inlet for water filling and an outlet for venting. See figure 19 for a typical arrangement of a test section and apparatus. The approximate end thrust force is given in table 10.

| DN (mm) | Cross Section Area (Cm2) | End Thrust Force (Kg) |         |         |         |         |
|---------|--------------------------|-----------------------|---------|---------|---------|---------|
|         |                          | Test Pressure (Barg)  |         |         |         |         |
|         |                          | 4.5                   | 9       | 12      | 13.5    | 15      |
| 100     | 100                      | 461                   | 921     | 1,227   | 1,381   | 1,534   |
| 150     | 209                      | 958                   | 1,915   | 2,553   | 2,872   | 3,191   |
| 200     | 356                      | 1,635                 | 3,270   | 4,359   | 4,904   | 5,449   |
| 225     | 443                      | 2,033                 | 4,065   | 5,420   | 6,097   | 6,774   |
| 300     | 765                      | 3,508                 | 7,015   | 9,353   | 10,522  | 11,691  |
| 400     | 1,353                    | 6,205                 | 12,410  | 16,547  | 18,615  | 20,683  |
| 450     | 1,706                    | 7,824                 | 15,648  | 20,863  | 23,471  | 26,079  |
| 500     | 2,099                    | 9,630                 | 19,260  | 25,680  | 28,890  | 32,100  |
| 550     | 2,534                    | 11,624                | 23,247  | 30,996  | 34,870  | 38,745  |
| 600     | 3,009                    | 13,805                | 27,609  | 36,812  | 41,413  | 46,015  |
| 700     | 4,083                    | 18,729                | 37,458  | 49,943  | 56,186  | 62,429  |
| 900     | 6,720                    | 30,826                | 61,652  | 82,203  | 92,478  | 102,754 |
| 1200    | 11,902                   | 54,595                | 109,190 | 145,586 | 163,784 | 181,982 |

Table 10: End thrust during pressure testing

(Values are given in kilograms - some diameter/pressure combinations might not be available)

### 8.1.2 Bracing Test-Ends and Set-Up

Due to the thrusts occurring at the testing end-caps, temporary blocks must be used to brace the pipe end-caps in order to prevent line displacement as indicated in the figure 19.

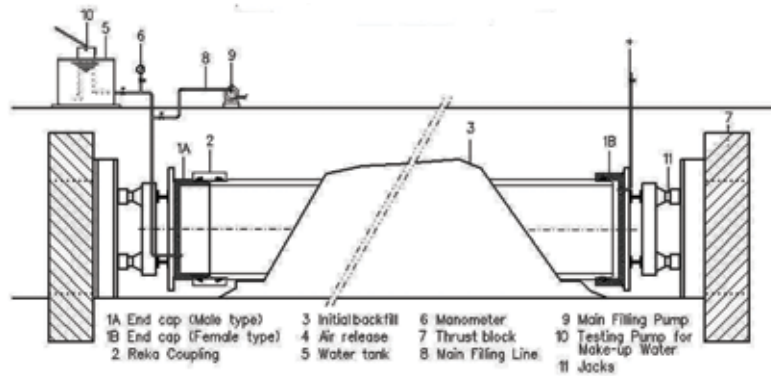

Figure 19: Thrust blocking pipe ends and site pressure test set up

In the gap between the end of the pipeline and the block, jacks should be placed as shown in figure 19. The last pipe length should also be wedged on both sides, at the top and at the bottom, in order to prevent lateral and vertical movements. Sandbags can be used for this purpose.

**Note 7:** It may be possible to reduce the size of the concrete blocks by driving into the ground, several meters deep, two or more steel sheet piles back to back. Sheet piles so positioned behind the concrete blocks will provide additional bracing.

### 8.1.3 Filling the Line with Water

The line should be filled slowly and evenly with water from the lowest end point. At high points, air vents will be installed to release the entrapped air. After filling the line with water, the test section should be left for stabilization. The filling rate of the line with water should be controlled

to ensure a proper venting and to keep the flow velocity below the allowable limit.

Following the stabilization period and after expelling all the entrapped air out of the pipe test section, the release valves should be closed.



**Volume of water required:**

Table 11 indicates the approximate volume of water required in order to fill Wavistrong™ (H2O) Water Series pipes per 100 meter of pipeline.

| DN (mm) | Water volume (m <sup>3</sup> ) / 100 m of pipeline |
|---------|--|
| 80      | 0.5  |
| 100     | 0.8  |
| 150     | 1.8  |
| 200     | 3.1  |
| 250     | 4.9  |
| 300     | 7.1  |
| 350     | 9.6  |
| 400     | 12.6   |
| 450     | 15.9   |
| 500     | 19.6   |
| 600     | 28.3   |
| 700     | 38.5   |
| 800     | 50.3   |
| 900     | 63.6   |
| 1000    | 78.5   |
| 1100    | 95   |
| 1200    | 113  |

Table 11

**8.1.4 Pressurizing**

After the stabilization period, the pressure shall be raised gradually until the intended test pressure at the lowest point is reached.

Unless otherwise specified by the Engineer, the test pressure shall be equal to 1.5 times the intended working pressure of the pipeline section, but shall not exceed the pipe pressure class. Once the required test pressure is reached, the pressure should be maintained for a holding period.

During the pressure test, all joints should be visually inspected (where possible), and all visual leaks should be repaired. In case the test is not satisfactory, the locations of the leaks shall be determined and rectified, and all the line re-tested in the same manner as specified above. The test section shall be accepted only after successfully passing the above leakage test.

During the holding period, if the pressure drops, make sure that the thermal effect and the air entrapped is not the cause.

**Note 8:**

1. The Contractor should note that while pressure testing large diameter Wavistrong™ (H2O) Water Series pipe on site at pressures generally above 10 bars, there is a possibility of a slight rotation/pivoting of the Wavistrong™ (H2O) Water Series coupling. This is the result of uneven pressure against the various parts of the coupling, and is inevitable during normal joint assembly where a perfectly centered and aligned joint can never be achieved. In the unlikely event that one or more joint starts to rotate or to shift slightly during the pressure test, it is advisable to reduce the pressure, and to backfill the joints completely using selected, properly compacted backfill, prior to resumption of the pressure test. Any joint that has shifted significantly should be centered again before resuming the pressure test.
2. Test pressure of pipelines is related to the intended working pressure (Pw) in the pipes and not to the rated pressure class of the pipes (PN).

## 9. Pipeline Commissioning

After completing the hydraulic test, the line must be thoroughly flushed out and disinfected (in case of potable water lines), as specified by the engineer or local regulations. In the absence of any such regulations, the following guidelines may be followed.

Disinfecting potable water lines is normally performed using either of the following chemical mediums:

- Liquid Chlorine
- Sodium Hypochlorite solution
- Calcium Hypochlorite granules or tables

This gives a solution containing at least 20 to 25 mg/l of free chlorine initially. The disinfecting period is normally 24 hours after which the residual chlorine should not be less than 10 mg/l. After the 24 hour disinfecting period, the line is flushed and filled with potable water.

When commissioning a pipeline, first ensure that all air valves are fully opened to release entrapped air. Fill the line very slowly and evenly at velocities not exceeding 0.3 m/s. Do not open valves quickly and fully during filling. After releasing all air, close air valves and hydrants and open inlet valve fully. If the line is coupled to a pump, the inlet valve should be closed when the pump starts running. Later on, the inlet valve shall be opened slowly. The discharge valve should be closed slowly before shutting down the pump.

## 10. Air in Pipelines, Air-Valves, and Surge Control

Air in pressure pipelines can cause major operational problems. Typical problems induced by the presence of such air are the reduction in flow capacity because of reduced cross-sectional areas, and fluctuation in flow caused by expansion and contraction of the air pockets in the line. High surge pressures can result from the flow fluctuations, which cause sudden movements of the air from one location to another, followed by the slugs of water. Also, surge (water hammer) can occur in pipelines from opening and closing valves and from the start-up and shutdown of pumps.

### **Air can enter a pipeline from many locations:**

- On draining the line
- Negative surges (vacuum) causing air to enter at air valves in the pipeline
- At the intake source.
- Release of dissolved air from the water by temperature and pressure variation
- Draining parts of the pipeline or the pipe system during normal shut-down

In the first instance, air shall be prevented from entering the line. This will reduce operational difficulties.

### **Suggested solutions for controlling entrapped air in pipelines are as follows:**

- The intake point should be provided with low water level pump cut-off.
- Release of air: Air dissolved in the water at the intake and released due to temperature and pressure fluctuations cannot be prevented. However, the quantities of such air are not large and provisions for releasing the air can be made by the means of air valves. Proper selection of air valves is essential.
- While draining the line, air cannot be prevented from entering the line. Large orifice air valves should be provided for exhausting the air during refilling. Long filling times will allow the complete release of air.
- Negative surges (vacuum) - Large volumes of air may be involved here and can cause serious operational problems. The best way to prevent air from entering under these conditions is by proper design to eliminate the possibility of water column separation.

Studies have shown that suddenly released entrapped air under apparently static conditions creates a situation similar to a water hammer. Generated pressures can be of the order of several times the pipeline test pressure. Any pipeline material can be seriously affected by the quick increase in the magnitude of pressure loads.

**Remedial actions against entrapped air and water hammer are the following:**

- 1- Lay the pipeline essentially to grade wherever is possible, avoiding major slopes. It may be advantageous to create artificial high points by providing a small slope of around 1-2 mm per m to facilitate air collection at high points.
- 2- Automatic continual acting air release valves should be used at all major high points. Almost all the air release valve manufacturers limit the maximum distance between air release valves to around 750 meters.
- 3- Air should be sucked out from the pipeline slowly.
- 4- Maximum filling velocity of the pipeline is 0.3 m/s.
- 5- Use  $d/D = 1/10$  to  $1/15$ .  
d = diameter of air release valve  
D = pipe diameter
- 6- Using motorized actuated valves is an effective means of limiting positive surges to an acceptable level by controlling the rate of opening and closing of the valves.
- 7- Flywheels on pump motors allow the pump to keep on running for a short period of time after any power shutdown, before it gradually stops.

## 11. Repair and Replacement of Pipe

The replacement of a pipe or a fitting in a double bell coupling joints system is similar to that of a closure (i.e. laying of the last length of pipe or fitting which closes or completes the line or a section of the line).

To replace a damaged pipe, cut out a ring from its length and pull out the remaining two sections from the couplers that connect it to the adjacent pipes. Pull out these couplers and replace the sealing rings. Insert the new pipe as indicated below:

- Carefully measure the gap where the replacement piece has to be fitted. The replacement piece must be 32 mm shorter than the length of the gap. The pipe must be well centered, and an equal clearance of 16 mm must be left between the inserted pipe and the adjacent ones.
- Use a special pipe with long (double) machined ends especially ordered from the Wavistrong™ (H2O) Water Series Manufacturer.
- Mount the couplers into the calibrated ends of the new pipe after abundantly lubricating the ends and the sealing rings. IT will be necessary to gently help the second sealing ring over the chamfered end of the pipe.
- After cleaning them thoroughly, lubricate the ends of the two adjacent pipes.
- Insert the pipe in its final position and pull each coupler over the adjacent pipe up to the home line.

## 12. Tapping Wavistrong™ (H2O) Water Series Water Mains

Refer to manufacturer for further details.

## Appendix I

### Approximate weight of Pipe and Couplings

| DN (mm) | Pipe (kg/m) | Couplings (kg) |
|---------|-------------|----------------|
| 100     | 4           | 2              |
| 150     | 6           | 3              |
| 200     | 8           | 4              |
| 225     | 9           | 5              |
| 300     | 11          | 6              |
| 400     | 13          | 8              |
| 450     | 17          | 9              |
| 500     | 23          | 10             |
| 550     | 27          | 12             |
| 600     | 32          | 18             |
| 700     | 43          | 21             |
| 900     | 69          | 31             |
| 1200    | 122         | 49             |

## Appendix II

### Design Considerations for Pipelines Anchoring

The anchorage of pressure pipelines with rubber gasket joints is an important consideration for the safe and reliable operation of pressure pipelines.

If pressure pipelines are not anchored properly, the thrust loads can lead to the displacement of pipes and fitting sections. Thrust loads occur in pipelines wherever there is a change in diameter (e.g. reducers), a change in direction (Elbow, Tee, and Wye, etc.), or at dead ends (e.g. blind flanges, closed valves, bulk heads).

The determination of the thrust occurring in these situations is relatively simple. The figures and formulas in the following sections show the values of thrust occurring in various types of fitting configurations, common to all pressure pipelines. It is not the intention of this section to provide the design methods of thrust blocks. Specialized engineers should do these kinds of studies. The main design considerations of thrust blocks are as follows:

- The pressure is assumed to be acting on the joint area, and not on the internal pipe cross sectional area.
- Where concrete thrust blocks are used, they should be poured against undisturbed native soil. This is required to ensure proper load distribution, and that pressures induced by the surrounding soil do not exceed the maximum design bearing capacity. A soil investigation is recommended to establish the proper soil bearing capacities.
- Upward thrust forces can be absorbed by a combination of pipe weight, water in the pipe and the soil on top of the pipe. If these restraining forces are not sufficient, concrete blocks can be used to provide additional weight on top of the pipe.
- In the case of a horizontal thrust (the most common case), concrete blocks, both non-reinforced and reinforced are typically used. Pilings may also be used where native soils are unstable. It may also be possible to provide special axially reinforced pipes and to tie several sections of pipe together on both sides of an elbow for example. Tied pipe sections plus the weight of water plus the soil weight provide support which resists by friction the thrust forces in the pipeline. Tying of WAVISTRONG (H2O) Water Series pipe and fitting sections is normally done by laminated joints or alternatively by rubber gasket locked joints.

- The ground on which the pipes are laid normally absorbs downward thrust forces. The designer should note that where unstable soils are present, a proper foundation and bed constructed with good granular material shall be provided.
- The typical coefficients of friction (f) used for design purposes are the following :
  - Concrete on concrete 0.65
  - Concrete on dry clay 0.50
  - Concrete on wet clay 0.33
  - Concrete on gravel 0.65
  - Concrete on sand 0.40
- The table below provides typical soil bearing capacities (horizontal) which may be used for the design of thrust blocks. The designer should note that proper evaluation and identification of native soil is essential to determine the proper soil bearing capacity values.

| Soil type  | Bearing capacity (strength) (kN/m <sup>2</sup> ) |
|------------|--|
| Soft clay  | 48   |
| Silt       | 72   |
| Sandy silt | 144  |
| Sand       | 191  |
| Sandy clay | 287  |
| Hard clay  | 430  |

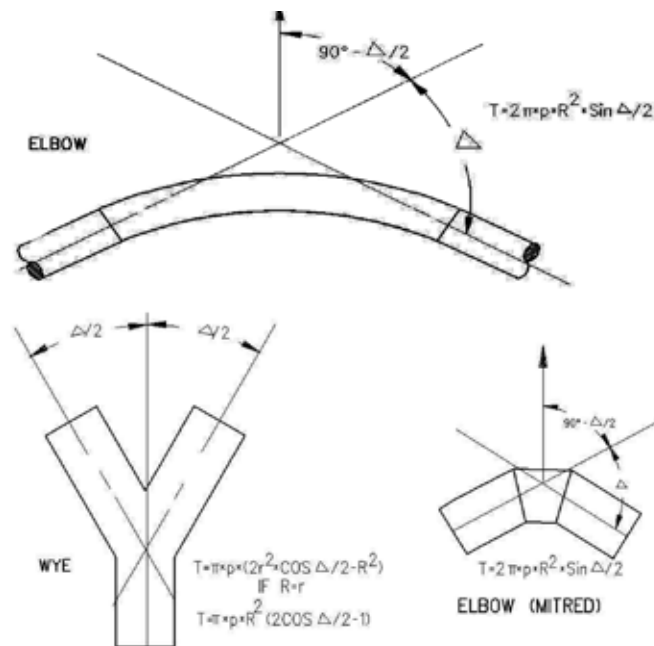



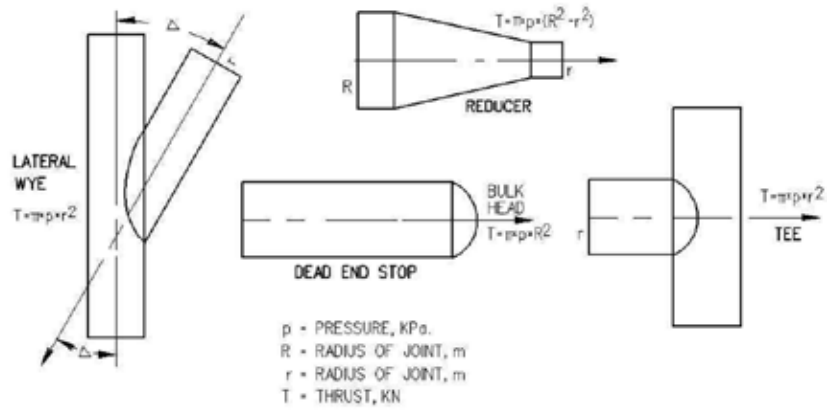

Figure II-1: Thrust in Fittings

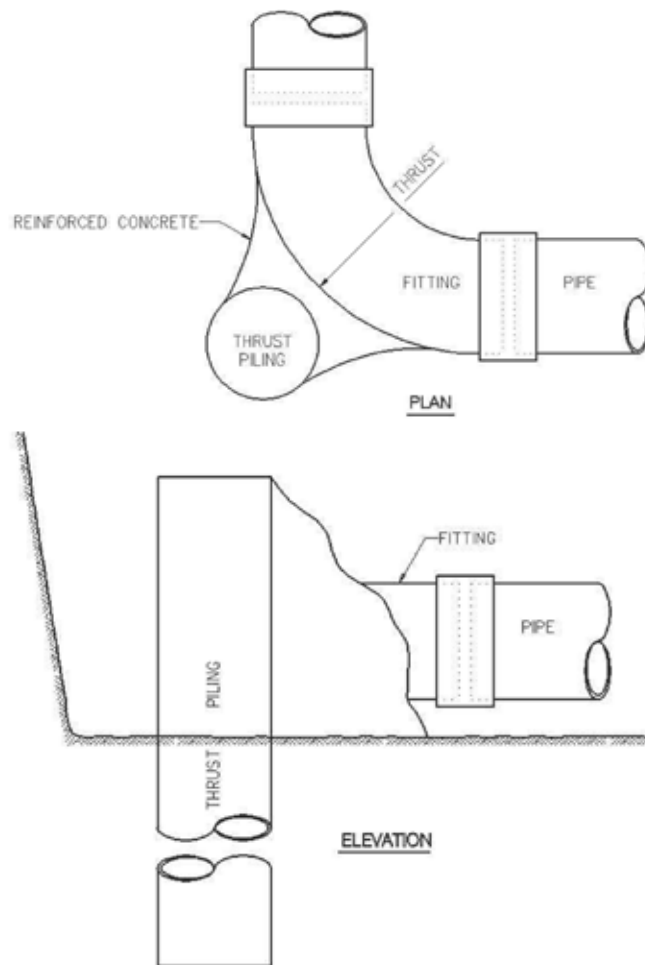

Figure II-2: Thrust Piling

## Appendix III

### List of References

- Fiberglass Pipe Institute Fiberglass pipe Handbook – 1989
- ASTM C924 M-89 Standard Practice for Testing Concrete Pipe Sewer Lines by Low-pressure Air Test Method [M]
- ASTM C969 M-94 Standard Practice for Infiltration and Ex-filtration Acceptance Testing of Installed Pre-cast Concrete Sewer Lines
- ASTM D1586 Standard Method for Penetration Test and Split Barrel Sampling of Soils.
- ASTM D2487 Classification of Soils for Engineering Purposes
- ASTM D1586 Standard Method for Penetration Test and Split Barrel Sampling of Soils.
- AWWA C950-01 Standard Specification for Fiberglass Pipe
- AWWA Manual M45 Fiberglass Pipe Design – Second Edition
- BS 8010 Part 1:89 Pipelines on Land - General
- BS 8010 Part 2.5:89 Pipelines on Land - Design, Construction & Installation - GRP Pipelines.
- BS 8010 Part 3:93 Pipelines-Sub-sea: Design, Construction & Installation.



