

WAVISTRONG™

Installation Guide

for GRE Pipe Systems



WAVISTRONG™

Installation Guide
for GRE Pipe Systems

TERMS OF USE

All information was correct at the time of going to press. However, we reserve the right to alter, amend and update any products, systems and services described in this brochure. We accept no responsibility for the interpretation of statements made.

© Copyright by Future Pipe Industries.

This document contains confidential and proprietary information. Reproduction or disclosure of any part of this document is only allowed with written authorisation by Future Pipe Industries. All rights are vested at Future Pipe Industries

TABLE OF CONTENTS

1 INTRODUCTION	3
1.1. Scope.....	3
1.2. References.....	3
1.3. Notification.....	4
2. PRODUCT INTRODUCTION	5
2.1. Systems.....	5
2.2. Pipe fabrication process.....	5
2.3. Advantages and disadvantages of GRE compared with steel.....	6
2.4. Product identification.....	6
3. MATERIAL HANDLING, STORAGE AND TRANSPORTATION	7
3.1. Handling.....	7
3.2. Storage.....	8
4. JOINING SYSTEMS AND PREPARATION METHODS	10
4.1. Conical-Cylindrical adhesive bonded joint.....	10
4.2. Taper-Taper adhesive joint.....	10
4.3. Laminate Joint.....	11
4.4. Flange Joint.....	11
4.5. Mechanical O-ring Lock Joint.....	12
4.6. Mechanical O-ring Joint.....	13
4.7. Mechanical Coupler.....	13
5. TOOLS AND MATERIALS	14
5.1. Tools.....	14
5.2. Materials.....	16
5.3. Check of incoming material.....	17
6. INSTALLATION OF UNDERGROUND PIPE SYSTEMS	18
6.1. Trench construction.....	18
6.2. System assembly.....	19
6.3. Backfilling.....	20
6.4. Special underground installations.....	21
6.5. Alignment.....	22
6.6. Settlement.....	22
6.7. Pipe cast in concrete.....	23
7. INSTALLATION OF ABOVEGROUND PIPE SYSTEMS	24
7.1. Supports.....	24
7.2. Pipe clamps.....	26
7.3. Valves.....	26
7.4. Bellows.....	26
7.5. Pipe connections through walls.....	27
7.6. Joining with other materials.....	28
7.7. UV-resistance.....	28
8. QUALITY ASSURANCE/QUALITY CONTROL	29
8.1. General.....	29
8.2. Joint traceability.....	29
8.3. Possible installation defects.....	29
9. FIELD TEST PROCEDURE	30
9.1. General.....	30
9.2. Preparation.....	30
9.3. Filling, stabilizing, testing and depressurizing.....	30
10. REPAIR	32
11. TOLERANCES	33
12. SAFETY PRECAUTIONS	34
12.1. Resin, hardener, adhesive- and lamination sets.....	34
12.2. Cutting, shaving and sanding.....	34
12.3. Environment.....	34

1. INTRODUCTION

1.1. Scope

This guide gives general information about various aspects that are relevant for the installation of Glassfiber Reinforced Epoxy (GRE) pipe systems. Respect for the requirements, methods and recommendations given in this guide will contribute to a successful operating pipeline system.

Authorized, trained and certified personnel can only contribute to a reliable pipeline system. Note that the remarks about the various joints in this document are for guidance only.

More specific and detailed information about underground and aboveground installations, as well as various joining methods, is given in manufacturers' referenced documents (see table 1.1.)



Fig. 1.1. Offshore unit

1.2. References

Following documentation gives required additional and detailed information about various subjects, which are described in this manual.

Table 1.1.

Section	Subject	Documentation
2.4.	Product Identification	Marking of products
4.1.;5.2.1.	Conical-Cylindrical adhesive bonded joint, CB-CS	Wavistrong assembly instructions Conical-Cylindrical (CB-CS) adhesive bonded joint
4.2.;5.2.1.	Taper-Taper adhesive bonded joint, TB-TS	Wavistrong assembly instructions Taper-Taper (TB-TS) adhesive bonded joint
4.3.	Laminate joint	Wavistrong Easy-Fit field laminate instructions
4.4.	Flange joint	Wavistrong flange guide
4.5.; 4.6.; 5.2.2.; 5.2.3.	Mechanical O-ring (lock) joint	Wavistrong Rubber Seal (Lock) Joint instructions
5.1.1.1.	Shavers	Wavistrong shaver instructions Conical-Cylindrical (CB-CS) adhesive bonded joint: * ID 25 – 50 mm * ID 80 – 250 mm * ID 200 – 400 mm Wavistrong shaver instructions Taper-Taper (TB-TS) adhesive bonded joint: * ID 80 – 300 mm * ID 250 – 600 mm
6.	Underground installations	Wavistrong installation of underground pipe systems
7.	Aboveground installations	Wavistrong installation of aboveground pipe systems
10.	Repair	Wavistrong repair manual ES system

1.3. Notification

This guide provides the following information:

- A general overview on tooling and materials for pipe system installation.
- A description of joining methods and systems.
- Requirements for handling, storage and transporting materials.
- Guides for installation of systems.
- Details about system control and applicable safety measures.

Please note that the instructions in this manual are for guidance only. Specifications written for a particular project will be normative.

We cannot describe all possible circumstances met in the field. For this reason, our experienced supervisors may deviate from given descriptions in order to achieve the optimum solution for the particular situation, using the latest techniques and methods.



Fig. 1.2. Water transmission



Fig. 1.3. Oil supply system

2. PRODUCT INTRODUCTION

2.1. Systems

GRE pipeline systems are made from glass fibers, which are impregnated with an aromatic- or cycloaliphatic amine cured epoxy resin.

This thermoset resin system offers superior corrosion resistance together with excellent mechanical, physical and thermal properties.

The glass fiber reinforced epoxy pipeline is resistant to the corrosive effects of mixtures with low concentrations of acids, neutral or nearly neutral salts, solvents and caustic substances, both under internal and external pressure.

A reinforced resin rich liner can protect the helical wound continuous glass fibers of the reinforced wall of the pipes and the structural reinforcement of the fittings internally.

2.2. Pipe fabrication process

GRE pipes are manufactured using the filament winding method. In this mechanical process, continuous glass fiber rovings are impregnated with epoxy resin.

The production of GRE pipe starts with the preparation of a steel mandrel, which may be provided with a socket mould. The dimensions of these tools determine the inner dimensions of the pipe and joint system.

Glass fibers are guided through a resin bath, which is filled with epoxy resin and are wound under constant tension in a specific pattern around the polished mandrel.

This process continues until the required wall thickness is reached. Generally, the higher the pressure class, the greater the wall thickness of the product will be. The winding process ends with curing the epoxy resin in an oven, extraction of the mandrel/mould from the product, finishing the product by cutting to length and machining the ends.

The products are subjected to visual and dimensional controls, as well as a hydro test program.

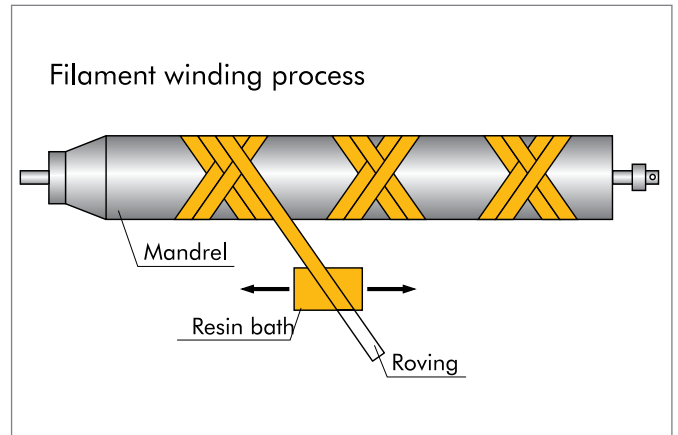

Fig. 2.1. Filament winding process

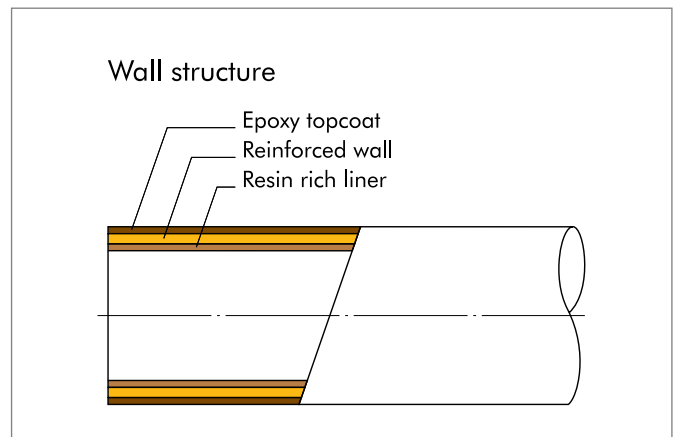

Fig. 2.2. Structure GRE pipe wall



Fig. 2.3. Spool manufacturing

2.3. Advantages and disadvantages of GRE compared with steel

2.3.1. Advantages

Glass Reinforced Epoxy pipe systems have a number of advantages over conventional pipe systems, of which the most important are:

- **Durable/corrosion resistant**
GRE piping is resistant, both internally and externally, to the corrosive effects of water, oil and many chemicals. Cathodic protection is not required.
- **Low weight/easy to install**
The specific weight of GRE is only 25 % of steel; due to the low weight, GRE pipeline components are easier to handle without using heavy (lifting) equipment.
- **No initial painting or conservation**
The epoxy topcoat on the outer surface of GRE pipe components is, under normal conditions, resistant to the influences of the installation environment and an additional external conservation is initially not required.

2.3.2. Disadvantages

Attention should be paid to the following disadvantages of GRE when comparing with conventional pipe systems, such as:

- **Impact resistance**
The pipe system is more susceptible to impact damage due to the brittle nature of the thermoset resin system.
- **Handling**
GRE installations require more and careful preparation due to other joining methods, handling- and transportation requirements and installation techniques.
- **Flexibility**
The flexible GRE piping system requires a specific design of supports.

2.4. Product identification

Products are marked with labels, which contain relevant product information.

For specific and detailed information, reference is made to manufacturers' documentation (see table 1.1.).



Fig. 2.4. GRE is durable/corrosion resistant



Fig. 2.5. GRE has low weight



Fig. 2.6. GRE needs no initial painting or conservation

3. MATERIAL HANDLING, STORAGE AND TRANSPORTATION

3.1. Handling

GRE products must be handled carefully to avoid any damage. Handling and transportation of GRE is not restricted by temperature. This section lists the most important requirements for handling materials before and after shipment and for storage.

3.1.1. Loading

Mind following requirements:

- Pipes, fittings and prefabricated parts (spools) shall be transported by suitable trucks, having flat bed floors.
- Forklifts may be used for handling if the forks are padded with a protective material such as rubber or plastic.
- Check for and remove any projections, nails or other sharp edges from the supporting floor before each load.
- Wood or rubber shall separate any contact of the truck or steel container with GRE products.
- Avoid direct contact between individual GRE products during transportation.
- Pipes and spools shall be lifted at least at two points by using nylon or canvas sling belts with a minimum width of 100 mm. Use the largest spool diameter to balance the load during the lift.
- Secure materials by wooden wedges and supports having a minimum width of 100 mm.
- Pipe supports shall be spaced at ≈ 3 m intervals, minimal 1 m from the ends; the support distance of nested pipes shall not exceed ≈ 2 m.
- Tie the products in place by using nylon or canvas sling belts.
- Chains and steel cables may never be used for lifting or fixation.
- Avoid support on sharp edges.
- Fittings can be properly transported in crates or on pallets.
- Flanges must be secured against sliding when stored on the sealing face.
- Pipe ends and machined surfaces must be protected (e.g. with PE-foil).



Fig. 3.1. Airfreight in wooden crate



Fig. 3.2. Spool handling



Fig. 3.3. Pipe handling



Fig. 3.4. Multiple support spool lifting

3.1.2. Unloading

The client is responsible for unloading ordered material, unless agreed otherwise.

Mind following:

- Use nylon or canvas sling belts with a minimum width of 100 mm.
- Lift standard pipe lengths at minimal two supporting points.
- Fix at least one sling belt around the spool section with the greatest diameter.
- Unload one (packed) item at a time.

3.2. Storage

In order to avoid damage to GRE products, the following recommendations shall be respected:

- Provide a flat and horizontal supporting surface.
- Do not store the pipes directly on the ground, onto rails or concrete floors.
- Ensure suitable supports such as clean, nail free wooden beams.
- Pipes shall be carefully stacked.
- Machined ends must be protected (e.g. with PE-foil).
- Bell and/or spigot ends may not touch each other.
- Pipes can be stacked economically by alternating the orientation of spigot- and socket end.
- Avoid pipe bending by locating supports between the layers of stacked pipe vertically above each other.
- Supports may be spaced at a maximum interval of 3 m and shall be placed ≈1 m from each pipe end.
- The allowable stacking height is 1.5 m or 2 layers, whichever is higher.
- Product diameters may flatten when stacked too high and/or too long, specially at elevated temperature.



Fig. 3.5. Protected pipe/spool ends



Fig. 3.6. Dual crane handling



Fig. 3.7. Packaging in crates



Fig. 3.8. Stacked pipe in stock

- Long-term storage of GRE material is recommended under protection of tarpaulins or PE-sheets.
- Stacked pipe must have side supports (e.g. wooden wedges) to prevent rolling or slipping.
- Unprotected flange sealing faces shall not be placed directly on the ground or on supporting floors.
- Spools shall not be stacked.
- No other materials shall be loaded on top of GRE products.
- Do not drop, walk, or stand on GRE products.
- Avoid point loading due to careless stacking.

Raw materials such as O-rings, gaskets, locking keys, adhesive kits, resin, hardener, woven roving and lubricants shall be stored in the original packaging, in a dry environment, at recommended temperatures.

The shelf life of adhesives and resins must be respected.

It is advised to order according the need.

If any damage is observed due to transportation or during installation (e.g. excessive scratches or cracks) contact the supplier.

Never use damaged materials.

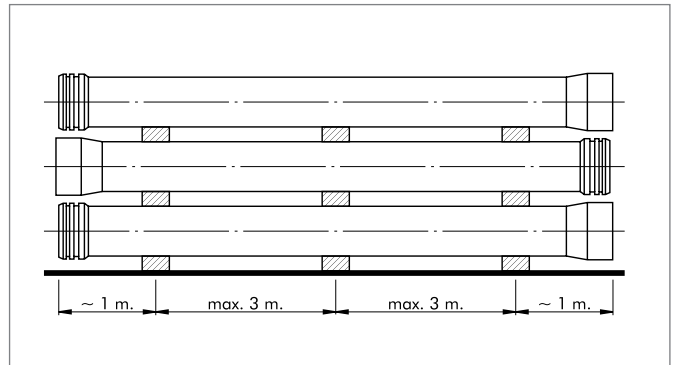

Fig. 3.9. Pipe stacking



Fig. 3.10. Wooden wedge side support



Fig. 3.11. Packing and storage of fittings

4. JOINING SYSTEMS AND PREPARATION METHODS

For the joining of GRE pipe components, various types of joints can be used. This section details the characteristics of each of these joints.

4.1. Conical-Cylindrical adhesive bonded joint

This type of adhesive bonded joint is supplied with a slightly conical socket and a cylindrical spigot. This joint allows for an accurate assembly length with narrow tolerance and may be used for above- and underground pipe systems.

For this adhesive joint the following tools and materials are required:

- Gloves, dust mask, safety glasses.
- Measuring tape, marker, bench, pipe fitters wrap around.
- Angle cutter, hand saw or jig saw.
- Shaver, grinding tools.
- Rubber scraper, pulling equipment, adhesive kit.
- Heating blanket or air gun, insulation blanket, digital temperature gauge.
- Cleaning brush, non-fluffy cleaning rags, cleaning fluids.

Summarized, the bonding procedure consists of: cutting, cleaning, machining, application of adhesive, joining and curing.

The installation time depends on proper preparation, diameter and personnel.

For specific and detailed information, reference is made to manufacturers' documentation (see table 1.1.).

4.2. Taper-Taper adhesive bonded joint

This adhesive bonded joint is supplied with a conical socket and conical spigot.

When comparing with the Conical-Cylindrical adhesive bonded joint this type of joint is also available in higher pressure classes.

For specific assembly dimensions, specific instructions are required.

The tools, materials, joining procedure and installation time for the Taper-Taper adhesive bonded joint are similar to those of the Conical-Cylindrical adhesive bonded joint.

For specific and detailed information, reference is made to manufacturers' documentation (see table 1.1.).

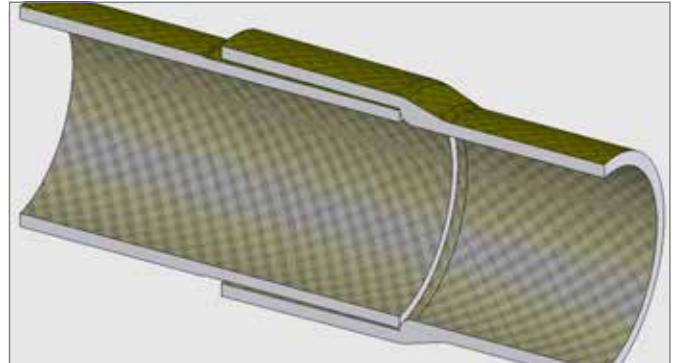

Fig. 4.1.a. Scheme Conical-Cylindrical adhesive bonded joint

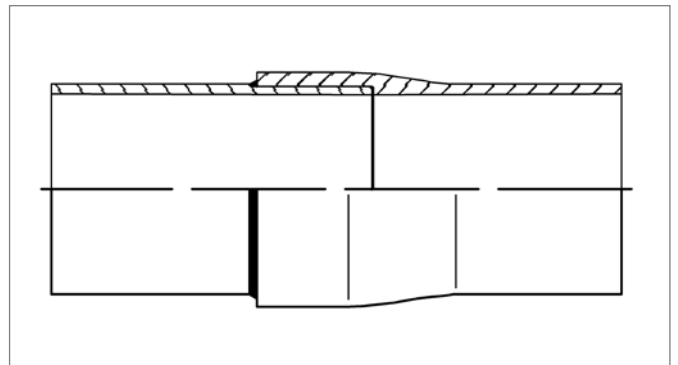

Fig. 4.1.b. Conical-Cylindrical adhesive bonded joint

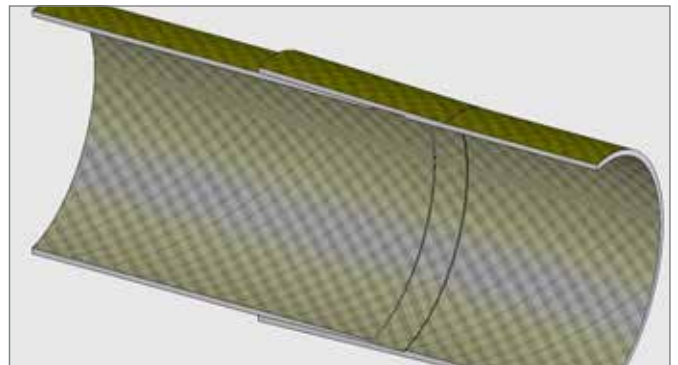

Fig. 4.2.a. Scheme Taper-Taper adhesive bonded joint

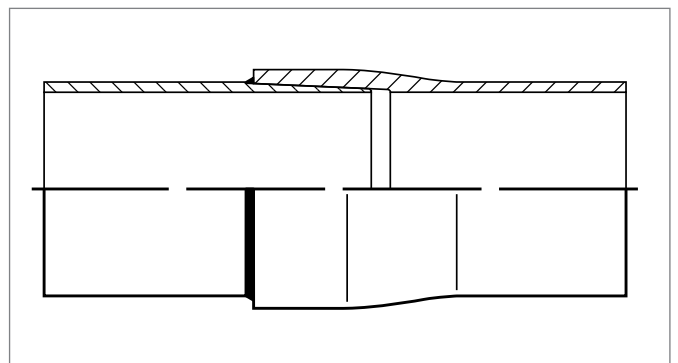

Fig. 4.2.b. Taper-Taper adhesive bonded joint

4.3. Laminate Joint

The laminate joint is used to join plain-ended pipe sections. After preparation of the pipe surfaces, a specific thickness of resin impregnated glass reinforcement is wrapped over a certain length around the pipes to be joined; the thickness and the length of the laminate are related to diameter and pressure.

This joint requires following tools/materials:

- Gloves, dust mask, safety glasses.
- Measuring tape, marker, pipe fitters wrap around.
- Angle cutter, hand saw or jig saw.
- Grinding tools, flexible support disc.
- Rubber scraper, scissors, brushes, resin, hardener and glass reinforcement.
- Air gun, gas burner or field oven, insulation blanket, digital temperature gauge.
- Cleaning brush, non-fluffy cleaning rags, cleaning fluids.

The successive activities for a laminate joint are: cutting, sanding, cleaning, mixing, fitting, laminating and curing.

For specific and detailed information, reference is made to manufacturers' documentation (see table 1.1.).

4.4. Flange Joint

The flange joint connects appendages and equipment as well as other lines of different materials. Based on the application and pressure, several types are available.

Bolts of GRE flange joints shall be tightened with limited torques; therefore, the use of a torque wrench is mandatory.

For a flange joint following tools and materials are required:

- Ring spanner, torque wrench.
- Bolts, nuts and washers.
- Gasket.

It is of major importance that GRE flanges are aligned with the counter flange. Misalignment may cause high stresses, which lead to premature material failure.

For specific and detailed information, reference is made to manufacturers' documentation (see table 1.1.).

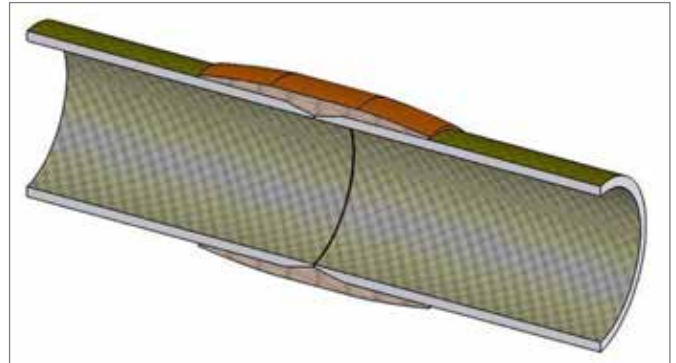

Fig. 4.3.a. Scheme laminate joint



Fig. 4.3.b. Laminate joint



Fig. 4.4. Flange joints



Fig. 4.5. Flange detail

4.5. Mechanical O-ring Lock Joint

The mechanical O-ring lock joint is a tensile resistant type of joint. This restrained type of joint can be used in unrestrained environments, e.g. aboveground. The following tools and materials are required to make such a joint:

- Pipe clamps and pulling equipment.
- Lubricant, O-ring, locking key(s) and plastic or wooden mallet to drive the locking key in position.
- Non-fluffy cleaning rags and cleaning fluids.

The assembly procedure starts with cleaning, mounting of the O-ring and lubricating surfaces, then mounting clamps, aligning, pulling the spigot in the socket and mounting the locking key(s). The joint can be disassembled but is not designed as such.

For specific and detailed information, reference is made to manufacturers' documentation (see table 1.1.).

4.5. A Mechanical REKA ring Lock Joint

The mechanical locking joint, designed to resist tension, is suitable for use in unrestricted settings, such as aboveground environments. To create this type of joint, the following tools and materials are necessary:

- Pipe clamps and pulling equipment.
- Lubricant, reka ring, locking key(s) and plastic or wooden mallet to drive the locking key in position.
- Non-fluffy cleaning rags and cleaning fluids.

The assembly process commences with cleaning, installing the REKA ring, and applying lubrication to surfaces. Subsequently, clamps are mounted, alignment is ensured, the spigot is pulled into the socket, and the locking key(s) are affixed. While disassembly is possible, the joint is not explicitly designed for this purpose.

Specific information can be obtained from the supplier of the coupler.

The joining necessitates the use of an Allen key, torque wrench and a ring spanner.

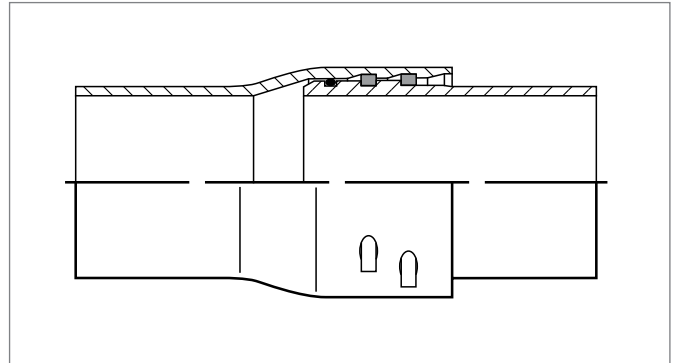

Fig. 4.6. Mechanical O-ring lock joint with two keys



Fig. 4.7. Mechanical O-ring lock joint with one key

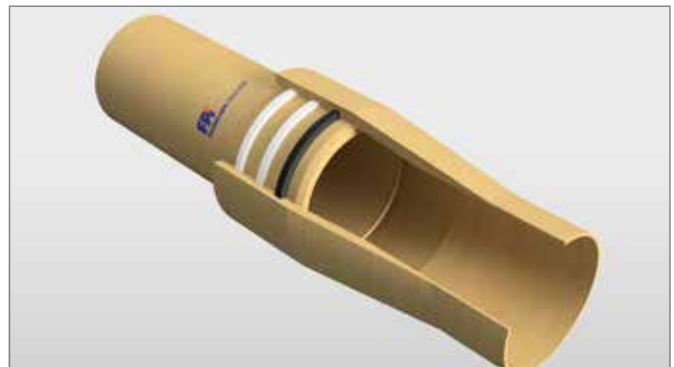

Fig. 4.7.A Mechanical REKA ring lock joint with two keys

4.6. Mechanical O-ring Joint

The mechanical O-ring joint is a non-tensile resistant type of joint. This unrestrained type of joint can be used in a restrained environment, e.g. underground.

This type of joint is made with the following tools and materials:

- Pipe clamps and pulling equipment
- Lubricant, O-ring.
- Non-fluffy cleaning rags, cleaning fluids.

Joining starts with cleaning, mounting of the O-ring and lubricating surfaces; then mounting clamps, aligning and pulling of the spigot in the socket.

For specific and detailed information, reference is made to manufacturers' documentation (see table 1.1.).

4.7. Mechanical Coupler

Generally, mechanical couplers are used for joining plain-ended GRE pipes to pipes made from other materials. A step coupler can join pipes with different outer diameters. This type of joint is unrestrained. These couplers can also be used for preliminary repairs.

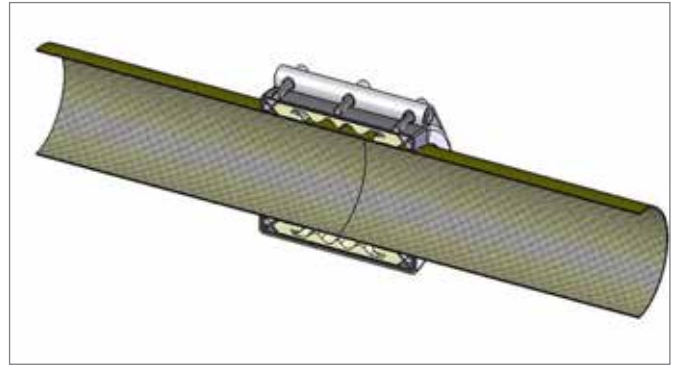

Fig. 4.8.a. Scheme mechanical coupler



Fig. 4.8.b. Various mechanical couplers

5. TOOLS AND MATERIALS

For details on tooling and materials reference is made to manufacturers' detailed documentation (see table 1.1.).

5.1. Tools

Tools are divided in two main categories: Non-consumables and Consumables.

5.1.1. Non-consumables

Non-consumable tools can be used multiple times.

5.1.1.1. Shaver

A GRE pipe shaver is a custom designed tool, which is used to prepare a spigot end for an adhesive bonded joint on a pipe.

Pipes are standard supplied with the appropriate spigot end, but an adjustment to length at site requires shaving of a spigot in the field.

A diamond cutter is mounted on the shaver arm. The shaver arm is mounted and centred on the clamp device, which is fixed against the inner surface of the pipe by expansion of the diameter of the clamp device.

The shaver arm rotates around the central shaft through the clamp device; the spigot end is shaped by machining of the diamond cutter.

5.1.1.2. Heating blanket

Heating blankets are designed to cure adhesive bonded and laminated joints.

Blankets are made from a coiled resistance wire, which is sandwiched between two layers of silicon rubber.

To control the temperature, each blanket is furnished with a thermostat.

It is important to store the heating blanket properly in order to keep this tool in an optimal condition.

Heating blankets shall never be folded; these blankets may only be stored flat or rolled.

5.1.1.3. Pullers and band clamps

Pullers and band clamps are used for the installation of Taper-Taper adhesive bonded joints, large diameter Conical-Cylindrical adhesive bonded joints and mechanical O-ring (lock) joints.



Fig. 5.1. Shaver set



Fig. 5.2. Shaving of a spigot end



Fig. 5.3. Heating blanket



Fig. 5.4. Pulled adhesive joint

Band-clamps with pulling lugs must be applied at both pipe ends to be joined. The positions of the pulling lugs shall face each other.

The Taper-Taper joint must be kept under tension until curing of the adhesive is completed, in order to avoid joint detachment.

Rubber protection pads are placed underneath the ratchets before tightening the band clamps. Put a wooden wedge between the pipe and the pulling lug to create a gap for mounting of the heating blanket.

For bonding of large diameters 3 to 4 pullers are required. Check the pullers on defects on a regular base.

5.1.1.4 Others

Other non-consumables may be required such as:

- Air gun, gas burner or field oven.
- Angle cutter, hand saw or jig saw.
- Pipe fitters wrap around.
- Grinding tool.
- Insulation blankets.
- Digital temperature gauge.
- Generator.

5.1.2. Consumables

Consumable tools can only be used once. Following tools are supposed to be consumable:

- Measuring tape.
- Pair of scissors.
- Marker.
- Sand paper/grinding discs P40 – P60.
- Brushes.
- Rubber scrappers, bucket.
- Cleaning fluids, joint lubricant.
- Dust masks, gloves and safety glasses.



Fig. 5.5. Curing of adhesive bonded joint under tension



Fig. 5.6. Consumables

5.2. Materials

5.2.1. Adhesive

Different types of adhesive are available depending on the application. Adhesive can be conductive or non-conductive.

An adhesive kit contains resin, hardener, mixing spatula and bonding instructions.

Adhesive kits contain chemicals that are sensitive to temperature and moisture.

It is important to check the expiry date of the adhesive, which is printed on the package.

Do not use adhesive or resin after indicated expiry date.

5.2.2. O-ring

A rubber O-ring provides the sealing of the mechanical O-ring (lock) joint. Standard O-rings are made of Nitril Butadiene Rubber (NBR).

Depending on the medium and/or temperature, other types of rubber can be supplied.

O-rings must be stored properly and flat, in a dry, cool and dark environment, free from dust and chemicals, which may attack the material.

Direct sunlight must be avoided.

5.2.3. Locking key

Locking keys block the longitudinal displacement of the spigot in the socket of a mechanical O-ring lock joint.

Locking keys must be stored in a dry and cool location without direct exposure of sunlight. Improper storage may affect the mechanical properties negatively.

For further details, reference is made to manufacturers' detailed documentation (see table 1.1.).



Fig. 5.7. Adhesive kit



Fig. 5.8. O-rings



Fig. 5.9. Locking keys

5.3. Check of incoming material

5.3.1. Quality check

The condition of containers, crates, boxes and pallets must be checked on possible damage upon arrival. If damage has occurred to any material package, the contents might be damaged too.

Check pipes and fittings on impact damage.

Raw materials, such as reinforcing material and chemicals, as well as tooling must be dry upon arrival.

The damaged state of materials and/or products when delivered must be reported and documented (e.g. clarified with pictures). Damaged materials shall be separated and quarantined from undamaged materials to avoid unintentional use.

5.3.2. Quantity check

Check the delivered quantities against the reported quantities on the packaging list. The recipient is advised to check the contents of the deliveries.

Quantity, size and configuration of materials and products should be physically checked against the data on the packing list.

Any deviation from the packing list must be reported immediately to the supplier.

6. INSTALLATION OF UNDERGROUND PIPE SYSTEMS

GRE pipes are used for various applications in various soils conditions.

Underground pipeline systems require accurate trench structuring, product assembly and installation. If applicable, the installation shall be performed in accordance with the requirements and/or conditions which are used in the system design.

For detailed information about underground installation, reference is made to manufacturers' documentation (see table 1.1.).

6.1. Trench construction

The trench construction highly depends on the soil parameters, such as type, density and moisture content.

The construction of the trench should comply with following requirements and recommendations:

- The trench shape is determined by the classification of the soil, which can be unstable or stable.
- Top sides of the trench must be cleared from rocks or any other sharp/heavy materials.
- The trench foundation shall consist of a compacted sand layer without stones or sharp objects.
- A hard and uneven trench foundation is loosened in order to prevent point loading.
- The trench is kept dry during installation; if necessary use a pumping system and drainage.
- The minimum width (W) at the bottom of the trench for a single pipe shall be:
 $W = 1.25 * OD + 300 \text{ mm}$.
- The space between the pipe and the trench wall must be 150 mm wider than the used compaction equipment.
- Respecting the pipe stiffness, the operating conditions of the system, the soil characteristics and wheel load the minimum burial depth amounts 0.8 m.
- The crown of the pipe must be installed below frost level.



Fig. 6.1. Trench in unstable soil



Fig. 6.2. Trench in stable soil

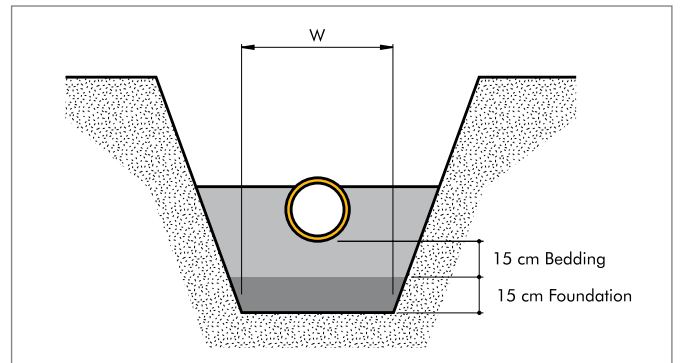

Fig. 6.3. General scheme of trench construction

6.2. System assembly

The assembly procedure of a piping system may vary per project. Generally, this procedure deals with positioning and joining of components in the plant.

6.2.1. Positioning components in the plant

After positioning of the pipe system elements next to the trench, these components have to be handled into final position in the trench.

- Small diameter pipe sections can be lowered manually using ropes, slings or light lifting devices.
- Large diameter piping requires heavier equipment during final positioning.
- To avoid damage the minimum bending radius of a pipe shall be respected.
- Avoid unwanted objects falling into the trench during lowering pipe sections.
- Use nylon sling belts or special designed equipment during product handling.



Fig. 6.4. Assembly activities

6.2.2. Joining of components

Respect next requirements and recommendations for joining of underground pipe systems:

- Inspect all products before installation.
- Components with mechanical O-ring joints shall be assembled in the trench.
- Adhesive bonded and laminated joints can be assembled either inside or outside the trench.
- Never move or disturb a joint during the curing process.
- Standard pipe lengths may be doubled in order to reduce the installation time.
- Ensure sufficient space around joints for proper alignment and joining.
- Keep the system centred in the trench.
- Respect the allowable joint angular deflection and pipe bending radius.
- Changes in directions in non-restrained pipeline systems must be anchored.
- Ensure stretching of the O-ring lock joints; this prevents axial displacement of the pipeline and overloading of fittings when pressurising the system.
- The pipeline can be stretched by loading the system at 0.8 * operating pressure. Mechanical stretching is recommended. Precautions shall be taken to avoid overloading of fittings.
- Branches shall be left free or are installed after stretching of the header completely.



Fig. 6.5. Assembly in the trench

6.3. Backfilling

Backfilling shall be performed according standard procedures. Trench filling, proper compaction and stabilizing of the system shall be performed in accordance with the requirements.

6.3.1. Procedure and requirements

The procedure and the requirements comprise:

- Temporary installation devices must be removed prior to backfilling.
- The maximum particle size for pipe zone embedment is related to the pipe diameter and is described in the backfill material specification.
- Dumping large quantities of backfill material at one spot on top of the pipe may cause damage; spread the applied backfill material.
- Backfill material shall be compacted in layers of 150 mm. The pipe may not be displaced due to backfilling.
- When reaching a compaction height of $0.3 \times ID$ below the crown of the pipe, compaction may be continued in layers of 300 mm.
- Each layer of backfill shall have a compaction grade of at least 85 % Standard Proctor Density (SPD).
- Compaction is performed on both sides of the pipe, never across the pipe. A vibrating plate with an impact force of approximately 3000 N is used.
- Do not use heavy pneumatic hammers or vibrating equipment until having reached a backfill level of 500 mm over the crown of the pipe.
- Avoid any contact between compaction tools and GRE product.

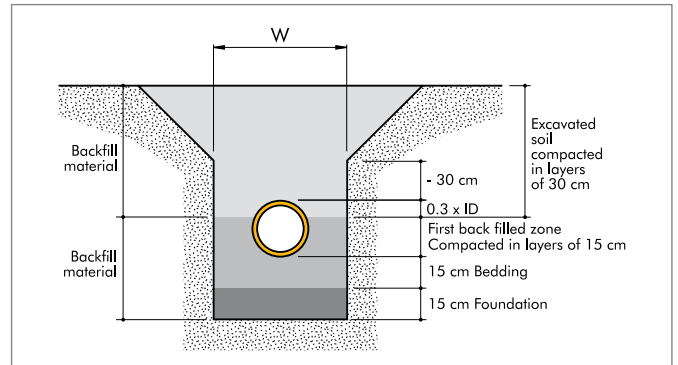

Fig. 6.6. Scheme trench construction stable soil

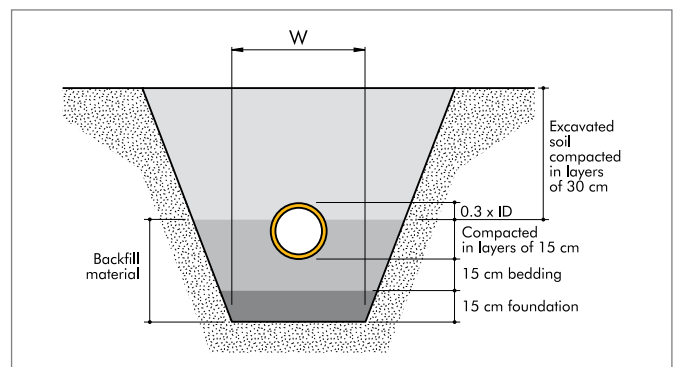

Fig. 6.7. Scheme trench construction unstable soil



Fig. 6.8. Pipe assembly in process in prepared trench

6.3.2. Backfill material specification

For classification of various backfill materials and types of embedment, reference is made to AWWA Manual M45 or ASTM D 3839.

Note that highly plastic and organic soil materials are not suitable for backfilling and must be excluded from the pipe zone embedment.

6.3.3. Other backfilling methods

Use of the saturation method does not give any better result than the above-described method.

The grade of compaction is lost if compaction by saturation is performed after mechanical compaction. When saturating the trench, avoid floating of the pipeline as well as erosion of the side support. Do not backfill if the ground is already saturated.

The saturation method may only be used for free draining soils, when the drainage pumps are kept in operation and the pipe system is completely filled with liquid.

6.4. Special underground installations

Road crossings and channel crossings might demand particular attention and requirements.

6.4.1. Road crossing

Precautions shall be taken to protect pipes, which cross underneath roads against the possible consequences of traffic loads.

Possible alternatives are:

- Jacket pipe.
- Relief plate.
- Burial depth.
- Pipe stiffness.

6.4.1.1. Jacket pipe

The GRE pipe is nested in a jacket pipe. In order to avoid direct contact between both pipes, spacers centre the GRE pipe. These spacers also support the GRE pipe at a maximum distance of 3 m. The jacket pipe should be longer than the width of the road.

6.4.1.2. Relief plates

Relief plates are used if pipes are installed at shallow depth in well compacted sandy soils or in case the soil- and traffic load cause an excessive loading or deformation of the GRE.

The plate is specially designed and dimensioned to minimise the transfer of wheel load on the pipe.



Fig. 6.9. Compaction of backfill material

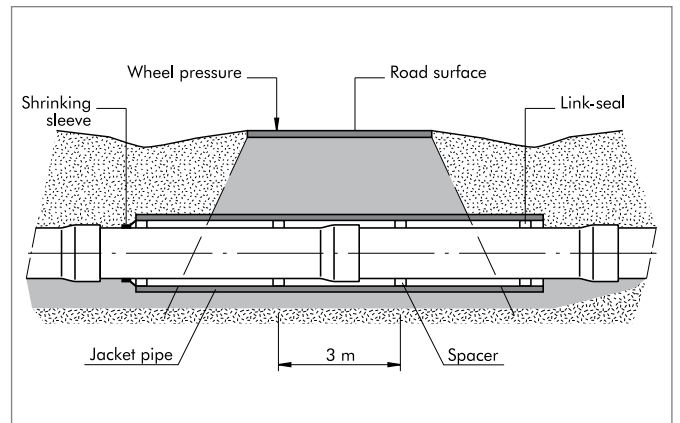

Fig. 6.10. Jacket pipe at road crossing

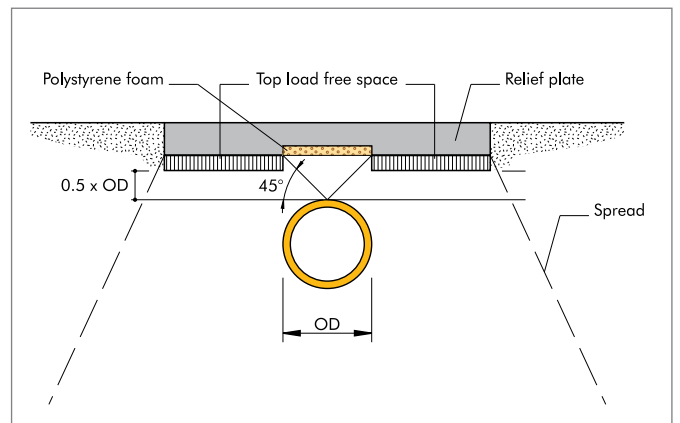

Fig. 6.11. Relief plate

6.4.2. Channel crossing

The common method to install channel crossings is by sinking of the channel crossing, after having assembled this section on the bank of the canal or river. The pipe section can be lowered using a floating crane or other lifting equipment; care should be taken to ensure sufficient pipe supports.

The process starts by sealing the ends of the pipe and then launching this section; the pipe keeps floating. Then, the pipe is filled and carefully sunk into its final position.

If the installation is performed using a cofferdam construction then flexible joints can be used for underwater piping; this makes the installation similar to an onshore assembly.

Note that underwater pipes should be covered sufficiently to prevent floating and damage (e.g. by anchors).

6.5. Alignment

Undulating land levels with minor difference in height can be followed by the flexibility of the system. Bending of a joint of an installed pipeline shall be avoided, unless allowable by system design.

6.6. Settlement

Flexible joints have to be installed in pairs; one joint is placed at the beginning of the deviation while the other is located at the end of this area in order to create a rocker pipe. The rocker pipe will act as a hinge.

The longer the rocker pipe, the higher the loads on the joints. This can be avoided by adding more joints that are flexible. Based on the soil parameters, the number of joints is determined.

Note that the length of the sections shall be limited in order to avoid excessive bending which may result in failure of pipe or joint.

Mechanical O-ring joints shall be installed at both ends to accommodate further settlements.

The allowable angular deflection shall not be exceeded.



Fig. 6.12. Launching of a channel crossing



Fig. 6.13. Pipe alignment

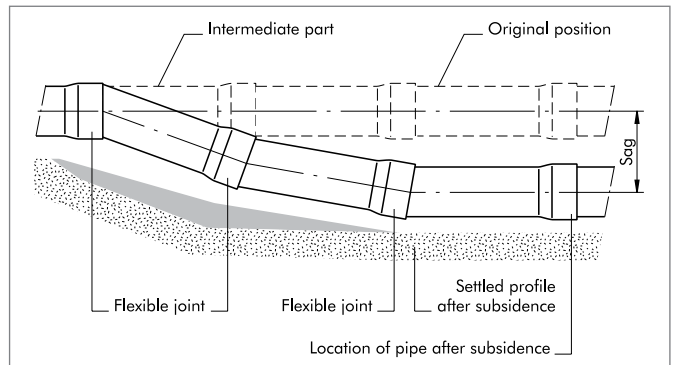

Fig. 6.14. Settlement

6.7. Pipe cast in concrete

In some cases, pipe systems may be cast in concrete. Such applications require following:

- Do not pour concrete directly onto pipe.
- The vibrating poker must be kept at least 300 mm away from the pipe.
- The pipe system must be pressure tested prior to casting.
- Cradles are provided with steel clamps and rubber lining in order to prevent floating.
- Buckling of the pipe during casting can be prevented by loading the system on internal pressure.

Note that concrete shrinks when setting; this may result in extra loading of the GRE pipe system. Ensure that the allowable pressure in the pipeline system is not exceeded by using pressure relief valves.

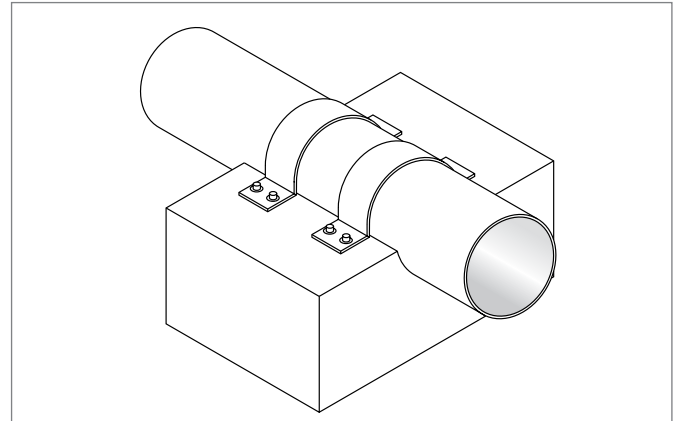

Fig. 6.15. Pipe cast in concrete

7. INSTALLATION OF ABOVEGROUND PIPE SYSTEMS

Aboveground pipe systems may be subjected to various loadings resulting from operation of the system.

If applicable, the installation shall be performed in accordance with the requirements and/or conditions which are used in the system design. Next to the information in this section, reference is made to specific manufacturers' documentation (see table 1.1.).

7.1. Supports

Supports not only provide system fixation, loading relief and clinching, but also protection. Prior to installation, supports are checked for location, type and span as detailed in drawings and specifications of the project.

Supports can be differentiated as fixed, guided sliding and free sliding supports.

7.1.1. General

Functional pipe supporting can be obtained with the aid of system design analysis.

Following aspects need to be respected:

- Pipes resting on sleepers are supplied with 180° saddles, which are adhesive bonded to the pipe at the support location to protect the pipe against wear damage from possible pipe movements.
- The length of the wear saddle must be 50 mm longer than the calculated pipe displacement plus the support width.
- Allow pipe expansion within a clamp.
- In vertical pipe assemblies, the sockets of O-ring joints shall point downwards, so water cannot be trapped in the socket.

Entrapped water in the socket may cause joint damage when freezing.

- For clamp dimensions, reference is made to manufacturers' detailed documentation.
- Pipes with mechanical O-ring joints require minimal one support per pipe length. The distance of the support to the joint is maximal 20 % of the pipe length.



Fig. 7.1. Aboveground pipe system



Fig. 7.2. Pipe supports



Fig. 7.3. Marine application

7.1.2. Fixed support points

Fixed points may never be realized by tightening the bolts of the pipe clamps. This may lead to pipe deformations and excessive wall stresses.

Mind the following requirements for fixed points:

- Fixation saddles shall be positioned on both sides, at the shoe side of the clamp.
- Laminated fixation saddles shall be applied on both sides of the clamp.
- When using non-restrained jointing systems each pipe shall be fixed.
- Each change of direction in a non-restrained pipeline shall be anchored to prevent pipe joints coming apart.
- Check whether the positions of pipe supports after testing are still in accordance with the installation requirements. The supporting elements might be dislocated due to test pressure.

Note that the mechanical O-ring lock joints must be fully stretched to avoid movement of pipe sections and consequently possible overloading. For further details on this type of joint, reference is made to manufacturers' documentation (see table 1.1.).



Fig. 7.4. Support with fixed point



Fig. 7.5. Fixed point with adhesive bonded saddles

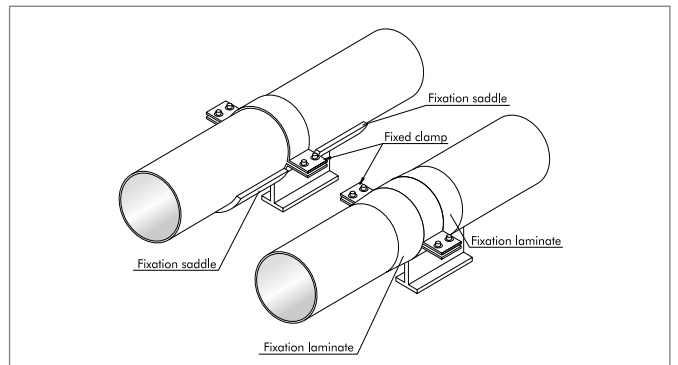

Fig. 7.6. Collars on both sides of the pipe clamp

7.2. Pipe clamps

Various types of pipe supports are available. Following considerations must be respected:

- Avoid point loads by using clamps made of flat strips instead of U-bolts.
- The width of the strip is related to the pipe diameter. For large diameter pipe double clamps may be applied.
- The inside of the clamp is furnished with a rubber or cork liner to compensate the uneven pipe outer surface and to minimise abrasion due to pipe movement and vibration.
- Longitudinal movement in the clamps is not advised. Generally, movement between the clamp shoe and the support structure shall realize sliding of supports.

For detailed information on clamps, reference is made to manufacturers' documentation (see table 1.1.).

7.3. Valves

To avoid overstressing of pipes by the weight of valves or other heavy equipment it is advised to support pipe accessories on the flange bolts.

The load on the pipeline by operating the valve shall be carried by the support of the pipe structure. In case of a GRE flange mounted against a steel flange, the support is preferably fixed to the steel flange.

7.4. Bellows

GRE products can absorb low amplitude vibrations due to the flexible properties of the composite material.

To eliminate high amplitude vibrations caused by e.g. pumps and to compensate soil settlement or expansion of e.g. tanks joined with pipes, bellows can be applied.

Bellows facilitate dismantling of pipe sections, valves, orifice flanges and gaskets. This equipment also absorbs pipe movements due to cyclic pressure and/or temperature in pipe systems that are joined with relatively stiff adhesive bonded joints.

In many cases, bellows are directly joined to the vibrating item by means of flanges. Note that the pipe section next to the bellow shall be supported separately to absorb the pipe loads.



Fig. 7.7. Overhead supported pipeline



Fig. 7.8. Double pipe clamp



Fig. 7.9. Bellow

Bolt torque values, as specified by the bellow supplier, might deviate from the torque values specified by the GRE manufacturer.

For specific and detailed information reference is made to manufacturers' documentation (see table 1.1.).

7.5. Pipe connections through walls

Several alternatives are available for passing pipes through walls. In case of anticipated settlement of the wall or pipeline, flexible couplings must be installed on both sides of the wall.

The joints shall be positioned as close as possible outside the wall.

7.5.1. GRE pipe with sealing puddle flange

The factory made puddle flange consists of a GRE ring, which is laminated on the pipe.

7.5.2. Sand coated GRE pipe

The GRE pipe can be provided with a sand coating which is part of the topcoat. This outer layer offers an excellent adhesion between concrete and GRE.

7.5.3. Link seal

This type of wall penetration consists of several linked rubber elements, which fit in the circular space between the outer surface of a GRE pipe and the diameter of a hole in a wall.

A sufficiently smooth inner surface of the wall can be obtained by:

- Mounting a steel pipe section with water seal before pouring mortar.
- Drilling a hole with a crown drill having diamond inlays.
- Fixing a removable plastic casing pipe section before pouring mortar.

The rubber elements are linked together with bolts and form a rubber chain. The rubber sections are compressed by tightening the bolts. All components of the link seal can be made of various material qualities.

Link seals allow for some angular deflection and lateral movement. After having mounted the GRE pipe in the link seal the rubber elements are compressed by evenly tightening the bolts. The expanded rubber sections seal the room between GRE and concrete.

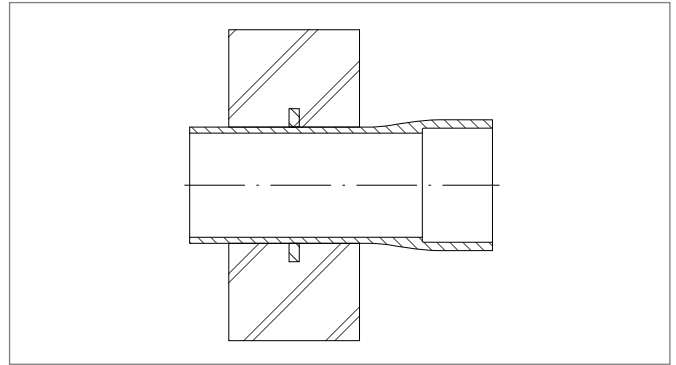

Fig. 7.10. Puddle flange

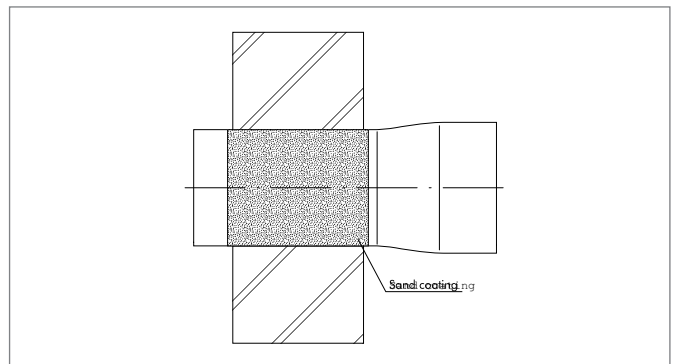

Fig. 7.11. Sand coated GRE pipe cast in concrete

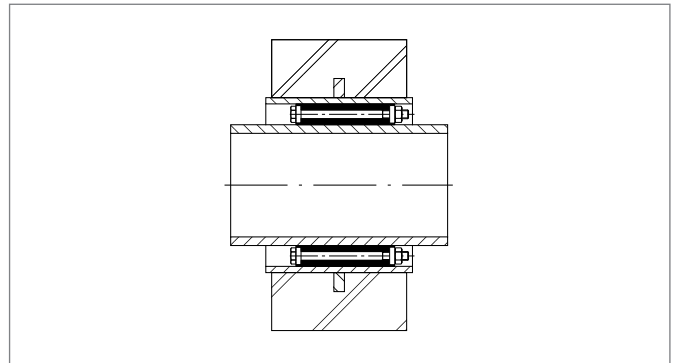

Fig. 7.12. Sketch of a link seal



Fig. 7.13. Link seal

7.5.4. Special sealing shape

This wall penetration consists of a steel pipe, which is provided with flanges. One of the flanges is profiled to fit a sealing element.

By tightening the nuts, the seal is compressed in the annular space between the flange and the pipe and provides an excellent seal.

7.5.5. Plain wall passing

When passing a pipe through a wall, the outer surface of the pipe must be protected with a flexible material, e.g. a 5 mm thick rubber layer, protruding 100 mm on both sides of the wall.

7.6. Joining with other materials

The most appropriate method to join objects of different materials is by using a flange. A mechanical coupler might be an alternative. For details about these joints, reference is made to manufacturers' documentation (see table 1.1.).

Flanges can be drilled according most of the relevant standards. When a flanged GRE pipe section is joined with a metal pipe section, the metal section must be anchored to avoid transmission of loads and displacements to the GRE pipe sections.

Instrument connections can be made using a saddle and a bushing.

7.7. UV-resistance

The topcoat of GRE pipes and fittings consists of a resin rich layer. This layer offers sufficient protection against UV-radiation.

When exposed to weather conditions the epoxy topcoat may be attacked on the long-term; this may result in a chalked outer surface.

After several years of operation, the chalked layer may be removed and replaced by a resistant, protective polyurethane paint coating. Contact the manufacturer for advice.

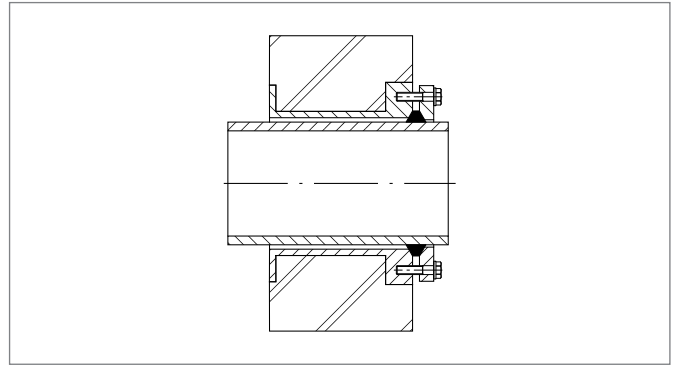

Fig. 7.14. Special sealing shape



Fig. 7.16. Joining with other materials

8. QUALITY ASSURANCE/QUALITY CONTROL

8.1. General

To assure good workmanship, only qualified and certified personnel shall be allowed to work on the installation of GRE pipeline systems.
For information, contact the GRE manufacturer.

Always strictly follow the installation manuals next to the necessary instruction guidelines. When making joints, it is necessary to execute the required steps in the correct sequence.

Never compromise on work quality and follow the instructions assigned from handling and storing through joining and installing GRE materials.

8.2. Joint traceability

As part of the quality control and on behalf of the traceability of adhesive bonded and laminate joint data, the following information should be registered during installation for each joint:

1. Name or registration info of the pipe fitter.
2. Joint identification (number).
3. Start-/end time of the curing process.
4. Heating blanket identification (number)
5. Identification (number) of adhesive kit
6. Temperature of heating blanket (optional).

8.3. Possible installation defects

Following table lists a number of defect types along with acceptance criteria and recommended corrective actions:

Table 8.1. Defect, acceptance criterion, corrective action

Defect	Inspection method	Cause	Acceptance criterion	Corrective action
Incorrect spool dimensions	Visual	Incorrect prefabrication	Can difference be compensated elsewhere in the system?	Accept
			Can system not be compensated?	Reject
Misaligned spools	Visual	Misaligned components e.g. flanges	Can difference be compensated elsewhere in the system?	Accept
			Can system not be compensated?	Reject
Misaligned joint	Visual	Movement during cure. Incorrect shave dimensions	Not permitted	Reject
Diameter restriction	Visual	Application of too much adhesive	Maximum height (h) of adhesive seam is $0.05 * ID$ or 10 mm, whichever is smaller	If accessible, remove by grinding
Impact, wear, or abrasive damage	Visual	Incorrect transport or handling	According to ISO 14692, Annex A, Table A1	Major defect: Replace Minor defect: Repair
Leaking joint	Hydro test	Joining not properly performed	Not permitted	Reject

9. FIELD TEST PROCEDURE

9.1. General

Before the installed pipeline system is operational, the system has to be hydro tested to ensure the integrity and leak tightness. Hydro testing of the pipeline system will be performed in two steps:

1. Integrity test.

The test pressure shall be increased over an agreed duration at an agreed pressure level in order to prove the maximum pressure resistance of the system.

2. Leak tightness test.

The test pressure shall be brought to an agreed level at which the joints can be inspected visually.

Pressure level and test duration can be stated in an Inspection and Test section of the Site Quality Plan.

All safety precautions must be applied.

It is important to test the integrity of the system first, to avoid the risk of injury during visual inspection.

All pressure gauges and pumps must be suitable and calibrated. Ensure that the pipeline can be vented and drained.

The pressure gauge must be mounted between a valve and the pipeline system in order to indicate the test pressure in the GRE system after having closed the valve, which is mounted after the pump. Due to the head of water, the pressure gauge should be located at the lowest point in the system. The pressure gauge should have a maximum scale reading of approximately twice the test pressure. If the system is not designed to withstand any negative pressure, then the system needs to be protected by a vent valve; this might occur during hydro testing.

Trapped air should be released by using vent(s).

The application of GRE pipeline systems may vary from long, (buried) line pipe applications to small skid piping systems.

Joint types may vary from laminate joints to mechanical joints with O-ring seal, with or without locking strip.

Each system requires its specific testing method. For each system, the test procedure can be described in the Inspection and Testing Plan (ITP). The ITP must be established before the project starts.

The advices for testing mentioned in the following paragraphs are for guidance only and are not mandatory.

9.2. Preparation

Prior to hydro testing, the following issues shall be checked:

- All material that should not be on the inside of the pipeline system shall be removed
- All joining procedures shall be completed.
- Trenches should be sufficiently backfilled and compacted to restrain the pipeline system; the joints should be left exposed.
- All supports, guides, and (temporary) anchors shall be in place and functional before pressurizing the system.
- All temporary supports and installation aids to erect the pipeline system shall be removed.
- Unless stated otherwise, all valves should be through-body tested.
- All check valves shall be removed to enable monitoring of the full line.
- Flange bolts shall be made up to the correct torque.
- The appropriate Health, Safety and Environment (HSE) requirements shall be respected.

9.3. Filling, stabilizing, testing and depressurizing

9.3.1. Filling and stabilizing

Fill the pipeline at the lowest point with water using a small diameter branch connection and vent the trapped air at the highest point(s) of the system. Long straight sections may be vented using an inflatable ball or foam pig to expel any air and impurities.



Fig. 9.1. Various pipe pigs

After filling, the line is pressurized gradually up to 0.8 * Design Pressure; the pressure shall be maintained for 24 hours in order to allow the system to set and the pressure to stabilise. For small diameter above ground systems, it is allowed to reduce the stabilising time.

9.3.2. Testing

The allowable test pressures shall be agreed with the GRE manufacturer.

Once the pressure is stabilised, the integrity of the pipe system is tested first in accordance with agreements.

Depending on the system a pressure drop might occur. In all cases, leakage of joints, pipes or fittings is not allowed. For safety reasons, an inspection of the system because of a possible leakage is not permitted when the pipeline is loaded at integrity test pressure level. This has to be mentioned in the ITP.

When the integrity test has been completed successfully, depressurise the system to leak tightness test pressure level. Duration of the leak tightness test normally depends on the time needed to inspect all joints, pipes and fittings visually.

It is strongly advised to test the line in sections, for example the length of one-day installation. The line is temporarily closed using, e.g. a test plug and a flange at the end. The blind flange should be provided with an air release valve.



Fig. 9.2. Field testing

After testing of the installed section the test plug needs to be pushed back about 2 meters by pressuring air via the air release valve. The excess water is released by opening the valve at the start of the line. After securing of the test plug, e.g. by inflation, the temporary flange connection can be removed and the assembly may proceed. The advantage of this method is that the test medium stays in the tested section and does not need to be re-filled for hydro testing of the next section.

Any leak caused by incorrect assembly of the joint can be detected easily.

Extreme movements shall be prevented by filling and compacting of the trench while the joints shall be left exposed.

Note that temperature changes over a 24 hours period will affect the pressure in a closed system.

A drop in pressure during the night does not always indicate that there is a leak in the system. When testing a system the ambient temperature shall be measured.

GRE material behaves different from steel due to the low weight, the flexibility of the joint and elasticity of the material.

In case of a failure during hydro testing, the line will move due to the sudden release of stored energy; there might be a risk of injury to personnel.

Note that testing with air or gas is extremely dangerous and should be avoided. Systems shall never be tested with a flammable fluid or gas. The advised test medium is water.

The manufacturer of GRE pipe systems does not take any responsibility for any damage resulting from testing.

The following causes may affect pressure drop and consequently result in following hydro test failures:

- Leakage of pipeline accessories.
- Leakage of gaskets.
- Leaking joints.
- Leakage of pipes.
- Leakage of fittings.

The system is considered to have passed the hydro test if there is nowhere test medium leaking from the tested piping system and there is no significant pressure loss that can be accounted for by usual engineering considerations.

9.3.3. Depressurizing

Depressurisation of the system must be carried out carefully to avoid a negative pressure.

10. REPAIR

It happens rarely that GRE pipes, joints and/or fittings have to be repaired. Repair on the pipeline system shall be performed in accordance with described instructions.

The performance of a repair shall be approved by the contractor and shall be performed in accordance with the pipe manufacturer's recommendations. Restore of the specified properties of the pipeline system after repair shall be demonstrated.

Leaks in pipe, fittings and joints shall be repaired by replacement of the defective part. In some cases, especially for buried systems, the accessibility to pipes and fittings may be difficult due to insufficient space.

Each application of a GRE pipe system and each type of product or design requires its own repair- and/or replacement procedure.

For further details, reference is made to manufacturers' documentation (see table 1.1.).

11. TOLERANCES

It is recommended to use the dimensional tolerances as shown in below table 11.1. and figure 11.1.

Table 11.1. Tolerances to dimensional reference

Internal Diameter (mm)	A	B	C	D	E	F
25 – 200	± 5 mm	± 3 mm	± 0.5 °	± 3 mm	± 1 mm	± 0.5 °
250 – 300	± 5 mm	± 3 mm	± 0.3 °	± 3 mm	± 1 mm	± 0.5 °
350 – 400	± 5 mm	± 3 mm	± 0.3 °	± 3 mm	± 2 mm	± 0.5 °
450 – 600	± 10 mm	± 5 mm	± 0.3 °	± 3 mm	± 2 mm	± 0.5 °
700 – 900	± 10 mm	± 5 mm	± 0.2 °	± 4 mm	± 3 mm	± 0.5 °
1000 – 1400	± 10 mm	± 5 mm	± 0.15 °	± 6 mm	± 3 mm	± 0.5 °

The maximum gap shall be limited to 6 mm.

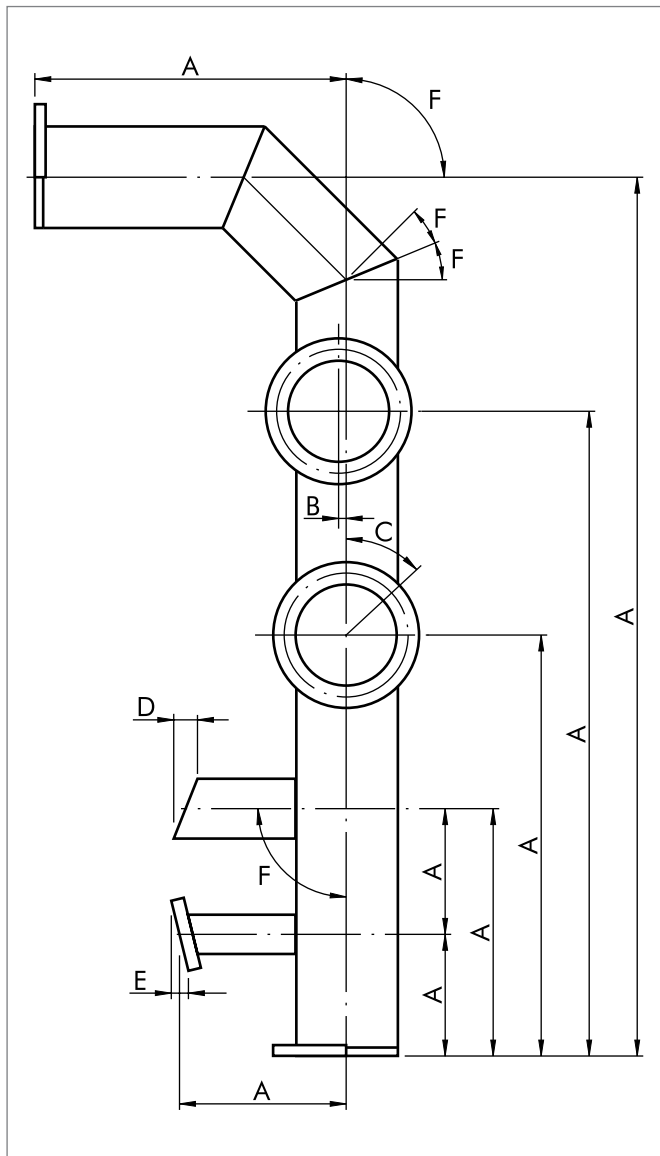

Fig. 11.1. Tolerances

Dimension A

- a. Face to Face dimensions.
- b. Center to Face dimensions.
- c. Location of attachments.
- d. Center to Center dimensions.

Dimension B

Lateral transition of branches or connections.

Dimension C

Rotation of flanges, from the indicated position.

Dimension D

End preparations.

Dimension E

Cut of alignment of flanges from the indicated position, measured across the full gasket face.

Dimension F

Angular deflection.

12. SAFETY PRECAUTIONS

The following safety precautions should be respected when using GRE products.

The required Risk- and Safety measures when using resin and hardener for adhesive or lamination sets are shown under the R- and S- code numbers, which are listed in manufacturers' documentation (see table 1.1.).

12.1. Resin, hardener, adhesive- and lamination sets

In order to avoid irritation of the respiratory system, satisfactory ventilation should be provided. If a system is hydro tested, adequate safety precautions must be taken, as a "safe test pressure" does not exist. Any pressure in itself is dangerous.

Experienced personnel must operate the test equipment. Persons not involved in the test or inspection are not allowed in the immediate area of the tested system. Only one person should be in charge and everyone else must follow his/her instructions.

Do not change anything on the pipe system when it is under pressure. Leaking joints may only be repaired after the pressure has been fully released.

The test equipment must be installed at a safe distance from the connection to the pipe system. If welding needs to take place, the GRE material must be protected from hot works.

12.2. Cutting, shaving and sanding

When cutting or grinding GRE materials the following personal protection is necessary to protect eyes and skin:

- A dust mask covering nose and mouth.
- A pair of safety goggles.
- Gloves and overall.
- Overall sleeves which are closed with adhesive tape to keep the dust out.
- Protective clothing to protect the body.
- A well-ventilated room or open air to perform the machining.

12.3. Environment

Always clean up the work area. GRE and cured adhesive are chemically inert and do not have to be treated as chemical waste.

Waste shall always be disposed in an environment friendly manner.



Fig. 12.1. Personal protective equipment

