

GEOSTRONG™

Tubing & Casing

High Pressure Downhole Tubing & Casing



GEOSTRONG™ Tubing & Casing

High Pressure Downhole Casing

TERMS OF USE

All information was correct at the time of publication. However, we reserve the right to alter, amend and update any of the products, systems and services described in this brochure.

We accept no responsibility for the interpretation of statements made.

© Copyright by **Future Pipe Industries**

This document contains confidential and proprietary information. Reproduction or disclosure of any part of this document is only allowed with written authorization by Future Pipe Industries.

Occasionally, Future Pipe Industries will provide updates to this catalogue. In order to assure that the reader is using the most current version, please visit our website at www.futurepipe.com

All rights are vested at **Future Pipe Industries**.

TABLE OF CONTENTS

1. Product	3
2. Product Description	4
3. Product Design And Range	5
4. Geostrong™ Standard Design	6
5. Geostrong™ High Performance	11

1. PRODUCT

Geostrong™ Tubing is a high-pressure tubing product constructed with high axial reinforcement and designed to efficiently transport fluids to/from the surface of the well.

Geostrong™ Casing is a high-pressure & high collapse resistant casing product designed for downhole well support, protection of producing formations, and prevention of groundwater contamination.

With product lengths ranging up to 39.4 feet (12 meters), Geostrong™ Tubing & Casing provides a fast and efficient installation along the complete well.

Geostrong™ Tubing & Casing ensures the integrity of a well as it offers the following advantages:

- Chemical/Corrosion Resistance (Resistant to aggressive soils and ground water, H₂S, CO₂, MIC etc.)
- Reduced Scaling Formations
- High pressure capability
- High collapse resistant
- Low Costs (Minimal maintenance; no coating or cathodic protection needed)
- Ease of Installation
- Long Term Reliability

Geostrong™ Tubing & Casing is the ultimate solution for the deployment of new wells and the replacement of corroded steel due to its high chemical resistance properties. Geostrong™ systems are recommended for use in both onshore & offshore applications like:

- Production wells
- Geothermal Wells (Low Enthalpy)
- Disposal wells (salt water, chemical effluent, and waste)
- Injection wells (salt water, CO₂)
- Municipal and commercial water wells
- Liners Repair of corroded steel



2. PRODUCT DESCRIPTION

- Nominal Sizes: 2-3/8" up to 26" (50 up to 600 mm)
- Collapse Pressures – Up to 3,700 psi (25.5 MPa)
- Internal Pressures – Up to 3,000 psi (20.7 MPa)
- Temperature – Up to 203°F (95°C)
- Resin System – Aromatic Amine Cured Epoxy
- Joining System – FPI's patented 4Rd, API 5B 8rd
- Threaded and Coupled Connection (T&C)
- Integral Joint (IJ)
- Product Length – Up to 39.4 feet (12 meters)
- Shop / Mill Hydrostatic Test – 100% of pipes tested at 1.25 times the pressure rating

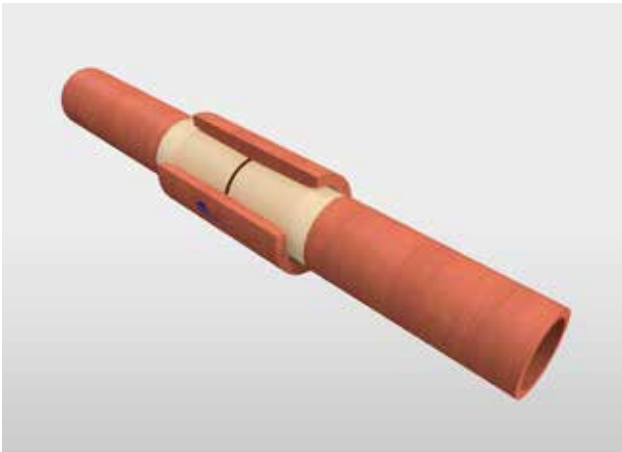

TC



IJ

3. PRODUCT DESIGN AND RANGE

Geostrong™ Tubing & Casing design is based on established criteria for downhole applications taking into consideration the internal pressure, collapse pressure, and axial ratings as the controlling parameters for designing at a given temperature. All pressure ratings and dimensions provided in this catalogue are defined for a temperature of 150°F (65°C). For applications requiring higher pressures and temperatures; contact Future Pipe Industries to obtain a suitable/custom product class.

Furthermore, applications engineering shall be applied on a case-by-case basis to ensure the well integrity and the optimal performance of the Geostrong™ Tubing & Casing product.

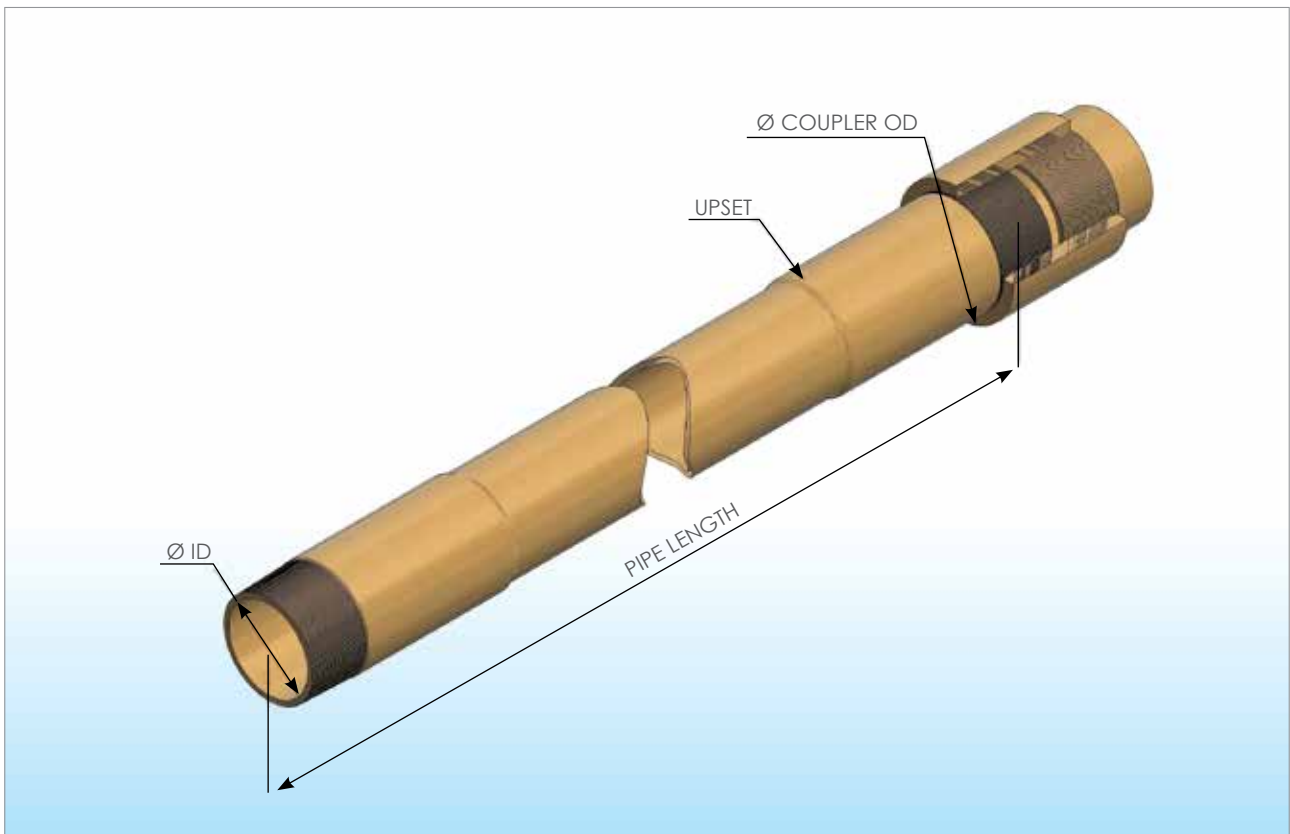

Drift diameter represents the effective/guaranteed inner diameter through which the outer diameter of an equipment or smaller string can pass. i.e. Equipment/strings with a larger outer diameter than the drift diameter should not be run into the existing well/string.

4. GEOSTRONG™ STANDARD DESIGN

The below mechanical properties are based on a standard temperature of 73.5°F (23°C), unless specified otherwise.

Typical Properties

Property	Test Method	Value	Units	Value	Units
Axial tensile stress (mechanical, uni-axial)	ASTM D2105	9,400	psi	65	N/mm ²
Hoop Bending Modulus	ASTM D2412	3.0	psi(x106)	20,500	N/mm ²
Axial Tensile Modulus	ASTM D2105	1.5	psi(x106)	10,500	N/mm ²
Coefficient of linear thermal expansion	ASTM D696	1.1 - 1.2	in/in/°F	2.0 - 2.2	mm/mm/°C (x10 ⁻⁵)
Thermal Conductivity	ASTM C177	0.17	BTU/ft/hour/°F	0.29	W/m/K
Specific Heat	-	0.22	BTU/lb/°F	921	J/kg/K
Glass Content (by mass)	ASTM D2584	75 ± 5 (for pipe) 70 ± 6 (for fittings)	%	75 ± 5 (for pipe) 70 ± 6 (for fittings)	%
Glass Content (by volume)	ASTM D2584	58 ± 7 (for pipe) 52 ± 6 (for fittings)	%	58 ± 7 (for pipe) 52 ± 6 (for fittings)	%
Density of the laminate	ASTM D792	0.07	lb/in ³	1,850	kg/m ³
Specific Gravity	ASTM D792	1.85	-	1.85	-
Barcol Hardness	ASTM D2583	35	-	35	-
Absolute pipe wall roughness	-	0.0004	inch	0.01	mm
Minimum flow coefficient (C)	Hazen Williams	150	-	150	-
Surface Roughness parameter (e)	AWWA M45	1.70	ft (x10 ⁻⁵)	5.18	m (x10 ⁻⁶)
Roughness coefficient (n)	Manning	0.009	-	0.009	-

Geostrong™ Standard Design - Product Range

500 Internal Pressure Rating

500 psi (3.45 MPa)

THREAD SIZE	Pipe Inside Diameter		Drift Diameter		Outside Diameter		Coupler Outside Diameter		Tensile Rating		Collapse Pressure Rating	
	in.	in.	mm	in.	mm	in.	mm	in.	mm	lbf	kgs	psi
13-3/8	11.81	300	11.69	296.8	12.35	313.6	15.39	390.9	42,300	19,187	50	0.3
16	13.15	334	13.02	330.8	13.74	349.0	17.33	440.1	52,400	23,768	50	0.3
16	13.78	350	13.65	346.8	14.39	365.6	17.33	440.1	57,500	26,082	50	0.3
18	15.75	400	15.62	396.8	16.44	417.6	19.37	491.9	75,100	34,065	50	0.3
20	17.72	450	17.59	446.8	18.49	469.6	21.53	546.8	95,100	43,137	50	0.3
22	19.69	500	19.56	496.8	20.54	521.6	24.02	610.0	117,400	53,252	50	0.3
26	23.62	600	23.50	596.8	24.63	625.6	28.52	724.4	169,000	76,657	50	0.3

750 Internal Pressure Rating

750 psi (5.17 MPa)

THREAD SIZE	Pipe Inside Diameter		Drift Diameter		Outside Diameter		Coupler Outside Diameter		Tensile Rating		Collapse Pressure Rating	
	in.	in.	mm	in.	mm	in.	mm	in.	mm	lbf	kgs	psi
10-3/4	8.86	225	8.73	221.8	9.46	240.2	12.13	308.1	36,400	16,511	150	1.0
11-3/4	9.84	250	9.72	246.8	10.50	266.8	13.24	336.4	44,900	20,366	150	1.0
13-3/8	11.81	300	11.69	296.8	12.59	319.8	15.48	393.1	64,700	29,347	150	1.0
16	13.15	334	13.02	330.8	14.02	356.0	18.10	459.8	80,200	36,378	150	1.0
16	13.78	350	13.65	346.8	14.68	372.8	18.10	459.8	88,100	39,961	150	1.0
18	15.75	400	15.62	396.8	16.77	426.0	20.16	512.1	115,100	52,208	150	1.0
20	17.72	450	17.59	446.8	18.86	479.0	22.41	569.3	145,600	66,043	150	1.0
22	19.69	500	19.56	496.8	20.94	532.0	25.01	635.2	179,800	81,556	150	1.0
26	23.62	600	23.50	596.8	25.12	638.0	29.70	754.4	258,900	117,435	150	1.0

1000 Internal Pressure Rating

1000 psi (6.9 MPa)

THREAD SIZE	Pipe Inside Diameter		Drift Diameter		Outside Diameter		Coupler Outside Diameter		Tensile Rating		Collapse Pressure Rating	
	in.	in.	mm	in.	mm	in.	mm	in.	mm	lbf	kgs	psi
6-5/8	5.43	137.8	5.30	134.6	5.93	150.6	7.56	192.0	18,600	8,437	300	2.1
7	5.91	150	5.78	146.8	6.45	163.8	7.81	198.5	22,000	9,979	300	2.1
7	6.20	157.6	6.08	154.4	6.78	172.2	7.69	195.2	24,300	11,022	300	2.1
9-5/8	7.87	200	7.75	196.8	8.58	218.0	11.04	280.3	39,200	17,781	300	2.1
10-3/4	8.86	225	8.73	221.8	9.65	245.0	12.20	310.0	49,600	22,498	300	2.1
11-3/4	9.84	250	9.72	246.8	10.71	272.0	13.34	338.9	61,200	27,760	300	2.1
13-3/8	11.81	300	11.69	296.8	12.84	326.2	16.05	407.6	88,100	39,961	300	2.1
16	13.15	334	13.02	330.8	14.29	363.0	18.88	479.5	109,200	49,532	300	2.1
16	13.78	350	13.65	346.8	14.97	380.2	18.88	479.5	120,000	54,431	300	2.1
18	15.75	400	15.62	396.8	17.10	434.4	20.96	532.3	156,700	71,078	300	2.1
20	17.72	450	17.59	446.8	19.23	488.4	23.30	591.8	198,300	89,947	300	2.1
22	19.69	500	19.56	496.8	21.36	542.6	26.00	660.4	244,800	111,039	300	2.1
26	23.62	600	23.50	596.8	25.62	650.8	30.88	784.4	352,500	159,891	300	2.1

1250 Internal Pressure Rating

1250 psi (8.6 MPa)

THREAD SIZE	Pipe Inside Diameter		Drift Diameter		Outside Diameter		Coupler Outside Diameter		Tensile Rating		Collapse Pressure Rating	
	in.	in.	mm	in.	mm	in.	mm	in.	mm	lbf	kgs	psi
6-5/8	5.43	137.8	5.30	134.6	6.05	153.6	7.64	194.0	23,700	10,750	600	4.1
7	5.91	150	5.78	146.8	6.58	167.2	8.08	205.3	28,100	12,746	600	4.1
7	6.20	157.6	6.08	154.4	6.91	175.6	7.83	198.9	31,100	14,107	600	4.1
9-5/8	7.87	200	7.75	196.8	8.76	222.4	11.07	281.3	50,000	22,680	600	4.1
10-3/4	8.86	225	8.73	221.8	9.84	250.0	12.56	319.1	63,300	28,712	600	4.1
11-3/4	9.84	250	9.72	246.8	10.93	277.6	13.79	350.2	78,200	35,471	600	4.1
13-3/8	11.81	300	11.69	296.8	13.09	332.6	16.61	422.0	112,600	51,075	600	4.1
16	13.15	334	13.02	330.8	14.57	370.2	19.65	499.2	139,500	63,276	600	4.1
16-3/4	13.78	350	13.65	346.8	15.27	387.8	20.71	526.0	153,200	69,490	600	4.1
18	15.75	400	15.62	396.8	17.44	443.0	21.75	552.5	200,100	90,764	600	4.1
20	17.72	450	17.59	446.8	19.61	498.2	24.18	614.3	253,300	114,895	600	4.1
22	19.69	500	19.56	496.8	21.79	553.4	26.99	685.6	312,700	141,838	600	4.1
26	23.62	600	23.50	596.8	26.13	663.8	32.06	814.4	450,300	204,253	600	4.1

1500 Internal Pressure Rating

1500 psi (10.3 MPa)

THREAD SIZE	Pipe Inside Diameter		Drift Diameter		Outside Diameter		Coupler Outside Diameter		Tensile Rating		Collapse Pressure Rating	
	in.	in.	mm	in.	mm	in.	mm	in.	mm	lbf	kgs	psi
6-5/8	5.43	137.8	5.30	134.6	6.17	156.8	7.66	194.6	29,100	13,200	1050	7.2
7	5.91	150	5.78	146.8	6.71	170.4	8.29	210.5	34,500	15,649	1050	7.2
7	6.20	157.6	6.08	154.4	7.05	179.0	7.97	202.4	38,100	17,282	1050	7.2
9-5/8	7.87	200	7.75	196.8	8.93	226.8	11.37	288.8	61,400	27,851	1050	7.2
10-3/4	8.86	225	8.73	221.8	10.03	254.8	12.93	328.5	77,700	35,244	1050	7.2
11-3/4	9.84	250	9.72	246.8	11.14	283.0	14.18	360.2	95,900	43,500	1050	7.2
14-1/4	11.81	300	11.69	296.8	13.36	339.4	17.24	438.0	138,100	62,641	1050	7.2
16	13.15	334	13.02	330.8	14.87	377.6	20.43	518.9	171,200	77,655	1050	7.2
16-3/4	13.78	350	13.65	346.8	15.57	395.6	21.53	546.8	187,900	85,230	1050	7.2
18-1/2	15.75	400	15.62	396.8	17.80	452.0	23.38	593.9	245,500	111,357	1050	7.2
21	17.72	450	17.59	446.8	20.01	508.2	26.10	663.0	310,700	140,931	1050	7.2

1750 Internal Pressure Rating

1750 psi (12.1 MPa)

THREAD SIZE	Pipe Inside Diameter		Drift Diameter		Outside Diameter		Coupler Outside Diameter		Tensile Rating		Collapse Pressure Rating	
	in.	in.	mm	in.	mm	in.	mm	in.	mm	lbf	kgs	psi
6-5/8	5.43	137.8	5.30	134.6	6.29	159.8	7.85	199.3	34,800	15,785	1650	11.4
7-5/8	5.91	150	5.78	146.8	6.84	173.8	9.19	233.5	41,200	18,688	1650	11.4
7-5/8	6.20	157.6	6.08	154.4	7.19	182.6	9.11	231.5	45,500	20,638	1650	11.4
9-5/8	7.87	200	7.75	196.8	9.10	231.2	11.68	296.7	73,200	33,203	1650	11.4
11-1/2	8.86	225	8.73	221.8	10.24	260.0	14.90	378.4	92,700	42,048	1650	11.4
11-3/4	9.84	250	9.72	246.8	11.37	288.8	14.56	369.9	114,400	51,891	1650	11.4
14-1/4	11.81	300	11.69	296.8	13.63	346.2	17.73	450.4	164,800	74,752	1650	11.4
16	13.15	334	13.02	330.8	15.17	385.2	21.20	538.6	204,200	92,624	1650	11.4
16-3/4	13.78	350	13.65	346.8	15.89	403.6	22.35	567.6	224,300	101,741	1650	11.4
18-1/2	15.75	400	15.62	396.8	18.15	461.0	24.21	614.9	269,000	122,016	1650	11.4

2000 Internal Pressure Rating

2000 psi (13.8 MPa)

THREAD SIZE	Pipe Inside Diameter		Drift Diameter		Outside Diameter		Coupler Outside Diameter		Tensile Rating		Collapse Pressure Rating	
	in.	in.	mm	in.	mm	in.	mm	in.	mm	lbf	kgs	psi
6-5/8	5.43	137.8	5.30	134.6	6.42	163.0	8.05	204.5	40,700	18,461	2450	16.9
7-5/8	5.91	150	5.78	146.8	6.98	177.4	9.46	240.4	48,200	21,863	2450	16.9
7-5/8	6.20	157.6	6.08	154.4	7.33	186.2	9.33	236.9	53,200	24,131	2450	16.9
9-5/8	7.87	200	7.75	196.8	9.29	236.0	12.03	305.5	85,600	38,828	2450	16.9
11-1/2	8.86	225	8.73	221.8	10.44	265.2	15.50	393.7	108,400	49,169	2450	16.9
12-1/2	9.84	250	9.72	246.8	11.60	294.6	17.44	442.9	133,800	60,691	2450	16.9
14-1/4	11.81	300	11.69	296.8	13.91	353.2	18.23	463.0	192,700	87,407	2450	16.9

2250 Internal Pressure Rating

2250 psi (15.5 MPa)

THREAD SIZE	Pipe Inside Diameter		Drift Diameter		Outside Diameter		Coupler Outside Diameter		Tensile Rating		Collapse Pressure Rating	
	in.	in.	mm	in.	mm	in.	mm	in.	mm	lbf	kgs	psi
7	5.43	137.8	5.30	134.6	6.55	166.4	9.25	235.0	46,800	21,228	2750	19.0
7-5/8	5.91	150	5.78	146.8	7.13	181.0	9.65	245.2	55,500	25,174	2750	19.0
7-5/8	6.20	157.6	6.08	154.4	7.48	190.0	9.54	242.4	61,300	27,805	2750	19.0
9-7/8	7.87	200	7.75	196.8	9.48	240.8	12.26	311.3	98,700	44,770	2750	19.0
11-1/2	8.86	225	8.73	221.8	10.65	270.6	16.17	410.8	124,900	56,654	2750	19.0
12-1/2	9.84	250	9.72	246.8	11.83	300.6	18.36	466.3	154,100	69,899	2750	19.0
14-1/4	11.81	300	11.69	296.8	14.19	360.4	18.74	476.0	222,000	100,698	2750	19.0

2500 Internal Pressure Rating

2500 psi (17.2 MPa)

THREAD SIZE	Pipe Inside Diameter		Drift Diameter		Outside Diameter		Coupler Outside Diameter		Tensile Rating		Collapse Pressure Rating	
	in.	in.	mm	in.	mm	in.	mm	in.	mm	lbf	kgs	psi
7	5.43	137.8	5.30	134.6	6.69	169.8	9.45	240.0	53,300	24,176	3100	21.4
7-5/8	5.91	150	5.78	146.8	7.27	184.6	10.13	257.3	63,200	28,667	3100	21.4
7-5/8	6.20	157.6	6.08	154.4	7.64	194.0	9.77	248.1	69,700	31,615	3100	21.4
9-7/8	7.87	200	7.75	196.8	9.67	245.6	10.17	258.4	112,300	50,938	3100	21.4

5. GEOSTRONG™ HIGH PERFORMANCE

The below mechanical properties are based on a standard temperature of 73.5°F (23°C), unless specified otherwise.

Typical Properties

Property	Test Method	Value	Units	Value	Units
Axial tensile stress (mechanical, uni-axial)	ASTM D2105	29,000	psi	200	N/mm ²
Hoop Bending Modulus	ASTM D2412	2.4	psi(x10 ⁶)	17,000	N/mm ²
Axial Tensile Modulus	ASTM D2105	2.5	psi(x10 ⁶)	17,200	N/mm ²
Coefficient of linear thermal expansion	ASTM D696	1.1 - 1.2	in/in/°F	2.0 - 2.2	mm/mm/°C (x10 ⁻⁵)
Thermal Conductivity	ASTM C177	0.17	BTU/ft/hour/°F	0.29	W/m/K
Specific Heat	-	0.22	BTU/lb/°F	921	J/kg/K
Glass Content (by mass)	ASTM D2584	75 ± 5 (for pipe) 70 ± 6 (for fittings)	%	75 ± 5 (for pipe) 70 ± 6 (for fittings)	%
Glass Content (by volume)	ASTM D2584	58 ± 7 (for pipe) 52 ± 6 (for fittings)	%	58 ± 7 (for pipe) 52 ± 6 (for fittings)	%
Density of the laminate	ASTM D792	0.07	lb/in ³	1,850	kg/m ³
Specific Gravity	ASTM D792	1.85	-	1.85	-
Barcol Hardness	ASTM D2583	35	-	35	-
Absolute pipe wall roughness	-	0.0004	inch	0.01	mm
Minimum flow coefficient (C)	Hazen Williams	150	-	150	-
Surface Roughness parameter (e)	AWWA M45	1.70	ft (x10 ⁻⁵)	5.18	m (x10 ⁻⁶)
Roughness coefficient (n)	Manning	0.009	-	0.009	-

Geostrong™ High Performance - Product Range

1000 Internal Pressure Rating

1000 psi (6.9 MPa)

THREAD SIZE	Pipe Inside Diameter		Drift Diameter		Outside Diameter		Coupler Outside Diameter		Tensile Rating		Collapse Pressure Rating	
	in.	in.	mm	in.	mm	in.	mm	in.	mm	lbf	kgs	psi
2-3/8	1.97	50.1	1.85	46.9	2.20	55.9	3.06	77.8	7,500	3,402	350	2.4
2-7/8	2.46	62.6	2.34	59.4	2.71	68.8	3.57	90.6	11,800	5,352	250	1.7
3-1/2	3.00	76.1	2.87	72.9	3.29	83.5	4.26	108.1	17,400	7,893	250	1.7
4	3.15	80	3.02	76.8	3.45	87.6	5.33	135.4	19,200	8,709	250	1.7
4	3.33	84.6	3.20	81.4	3.65	92.6	4.97	126.4	21,500	9,752	250	1.7
4-1/2	3.94	100	3.81	96.8	4.30	109.2	5.29	134.5	29,300	13,290	250	1.7
5-1/2	4.42	112.3	4.30	109.1	4.83	122.7	6.38	162.0	35,000	15,876	250	1.7
6-5/8	5.43	137.8	5.30	134.6	5.91	150.2	7.56	192.0	52,700	23,904	250	1.7
7	5.91	150	5.78	146.8	6.43	163.4	7.81	198.5	67,700	30,708	250	1.7
7	6.20	157.6	6.08	154.4	6.76	171.6	7.88	200.1	74,700	33,883	250	1.7
9-5/8	7.87	200	7.75	196.8	8.57	217.6	11.04	280.3	120,300	54,567	250	1.7
10-3/4	8.86	225	8.73	221.8	9.63	244.6	12.36	313.9	142,300	64,546	250	1.7
11-3/4	9.84	250	9.72	246.8	10.70	271.8	13.37	339.7	155,800	70,670	250	1.7
13	11.81	300	11.69	296.8	12.83	325.8	14.85	377.1	150,000	68,039	250	1.7

1250 Internal Pressure Rating

1250 psi (8.6 MPa)

THREAD SIZE	Pipe Inside Diameter		Drift Diameter		Outside Diameter		Coupler Outside Diameter		Tensile Rating		Collapse Pressure Rating	
	in.	in.	mm	in.	mm	in.	mm	in.	mm	lbf	kgs	psi
2-3/8	1.97	50.1	1.85	46.9	2.22	56.3	3.05	77.4	9,600	4,354	500	3.4
2-7/8	2.46	62.6	2.34	59.4	2.76	70.2	3.57	90.6	14,900	6,759	500	3.4
3-1/2	3.00	76.1	2.87	72.9	3.35	85.1	4.28	108.6	20,100	9,117	500	3.4
4	3.15	80	3.02	76.8	3.52	89.4	5.35	136.0	24,600	11,158	500	3.4
4	3.33	84.6	3.20	81.4	3.72	94.4	4.99	126.8	25,100	11,385	500	3.4
4-1/2	3.94	100	3.81	96.8	4.39	111.4	5.41	137.3	29,300	13,290	500	3.4
5-1/2	4.42	112.3	4.30	109.1	4.93	125.1	6.35	161.2	35,000	15,876	500	3.4
6-5/8	5.43	137.8	5.30	134.6	6.03	153.2	7.64	194.0	52,700	23,904	500	3.4
7	5.91	150	5.78	146.8	6.57	166.8	8.08	205.3	84,300	38,238	500	3.4
7	6.20	157.6	6.08	154.4	6.90	175.2	8.16	207.2	84,300	38,238	500	3.4
9-5/8	7.87	200	7.75	196.8	8.74	222.0	11.07	281.3	121,900	55,293	500	3.4
10-3/4	8.86	225	8.73	221.8	9.83	249.6	12.75	323.8	142,300	64,546	500	3.4
11-3/4	9.84	250	9.72	246.8	10.91	277.2	13.76	349.4	155,800	70,670	500	3.4
13-3/8	11.81	300	11.69	296.8	13.09	332.4	16.56	420.7	213,600	96,887	500	3.4

1500 Internal Pressure Rating

1500 psi (10.3 MPa)

THREAD SIZE	Pipe Inside Diameter		Drift Diameter		Outside Diameter		Coupler Outside Diameter		Tensile Rating		Collapse Pressure Rating	
	in.	in.	mm	in.	mm	in.	mm	in.	mm	lbf	kgs	psi
2-3/8	1.97	50.1	1.85	46.9	2.26	57.5	3.06	77.8	10,700	4,853	850	5.9
2-7/8	2.46	62.6	2.34	59.4	2.82	71.6	3.54	90.0	14,900	6,759	850	5.9
3-1/2	3.00	76.1	2.87	72.9	3.41	86.7	4.25	108.0	20,100	9,117	850	5.9
4	3.15	80	3.02	76.8	3.59	91.2	5.33	135.4	25,100	11,385	850	5.9
4	3.33	84.6	3.20	81.4	3.80	96.4	4.96	126.1	25,100	11,385	850	5.9
4-1/2	3.94	100	3.81	96.8	4.48	113.8	5.54	140.7	29,300	13,290	850	5.9
5-1/2	4.42	112.3	4.30	109.1	5.02	127.5	6.31	160.4	35,000	15,876	850	5.9
6-5/8	5.43	137.8	5.30	134.6	6.16	156.4	7.66	194.6	52,700	23,904	850	5.9
7	5.91	150	5.78	146.8	6.69	170.0	8.29	210.5	84,300	38,238	850	5.9
7	6.20	157.6	6.08	154.4	7.03	178.6	8.39	213.2	84,300	38,238	850	5.9
9-5/8	7.87	200	7.75	196.8	8.91	226.4	11.37	288.8	121,900	55,293	850	5.9
10-3/4	8.86	225	8.73	221.8	10.02	254.6	13.16	334.4	142,300	64,546	850	5.9
11-3/4	9.84	250	9.72	246.8	11.13	282.8	14.15	359.5	155,800	70,670	850	5.9
13-3/8	11.81	300	11.69	296.8	13.35	339.2	17.08	433.9	213,600	96,887	850	5.9

1750 Internal Pressure Rating

1750 psi (12.1 MPa)

THREAD SIZE	Pipe Inside Diameter		Drift Diameter		Outside Diameter		Coupler Outside Diameter		Tensile Rating		Collapse Pressure Rating	
	in.	in.	mm	in.	mm	in.	mm	in.	mm	lbf	kgs	psi
2-3/8	1.97	50.1	1.85	46.9	2.31	58.7	3.07	78.0	10,700	4,853	1350	9.3
2-7/8	2.46	62.6	2.34	59.4	2.87	73.0	3.54	90.0	14,900	6,759	1350	9.3
3-1/2	3.00	76.1	2.87	72.9	3.48	88.5	4.35	110.4	20,100	9,117	1350	9.3
4	3.15	80	3.02	76.8	3.66	93.0	5.55	141.0	25,100	11,385	1350	9.3
4	3.33	84.6	3.20	81.4	3.87	98.4	5.03	127.9	25,100	11,385	1350	9.3
4-1/2	3.94	100	3.81	96.8	4.57	116.0	5.68	144.3	29,300	13,290	1350	9.3
5-1/2	4.42	112.3	4.30	109.1	5.12	130.1	6.33	160.8	35,000	15,876	1350	9.3
6-5/8	5.43	137.8	5.30	134.6	6.28	159.4	7.85	199.3	52,700	23,904	1350	9.3
7-5/8	5.91	150	5.78	146.8	6.83	173.6	9.19	233.5	86,200	39,100	1350	9.3
7-5/8	6.20	157.6	6.08	154.4	7.17	182.2	9.14	232.3	86,200	39,100	1350	9.3
9-5/8	7.87	200	7.75	196.8	9.09	231.0	11.68	296.7	121,900	55,293	1350	9.3
11-1/2	8.86	225	8.73	221.8	10.23	259.8	14.77	375.1	159,500	72,348	1350	9.3
11-3/4	9.84	250	9.72	246.8	11.36	288.6	14.59	370.5	155,800	70,670	1350	9.3
14-1/4	11.81	300	11.69	296.8	13.62	346.0	17.80	452.0	234,400	106,322	1350	9.3

2000 Internal Pressure Rating

2000 psi (13.8 MPa)

THREAD SIZE	Pipe Inside Diameter		Drift Diameter		Outside Diameter		Coupler Outside Diameter		Tensile Rating		Collapse Pressure Rating	
	in.	in.	mm	in.	mm	in.	mm	in.	mm	lbf	kgs	psi
2-3/8	1.97	50.1	1.85	46.9	2.36	59.9	3.07	78.0	10,700	4,853	2000	13.8
2-7/8	2.46	62.6	2.34	59.4	2.93	74.4	3.56	90.5	14,900	6,759	2000	13.8
3-1/2	3.00	76.1	2.87	72.9	3.56	90.3	4.45	113.1	20,100	9,117	2000	13.8
4	3.15	80	3.02	76.8	3.74	95.0	5.51	140.0	25,100	11,385	2000	13.8
4	3.33	84.6	3.20	81.4	3.95	100.4	5.18	131.6	25,100	11,385	2000	13.8
4-1/2	3.94	100	3.81	96.8	4.66	118.4	5.84	148.3	29,300	13,290	2000	13.8
5-1/2	4.42	112.3	4.30	109.1	5.23	132.9	6.46	164.1	35,000	15,876	2000	13.8
6-5/8	5.43	137.8	5.30	134.6	6.41	162.8	8.05	204.5	52,700	23,904	2000	13.8
7-5/8	5.91	150	5.78	146.8	6.97	177.0	9.46	240.4	86,200	39,100	2000	13.8
7-5/8	6.20	157.6	6.08	154.4	7.32	186.0	9.40	238.9	86,200	39,100	2000	13.8
9-5/8	7.87	200	7.75	196.8	9.28	235.8	12.03	305.5	121,900	55,293	2000	13.8
11-1/2	8.86	225	8.73	221.8	10.43	265.0	15.41	391.4	159,500	72,348	2000	13.8
12-1/2	9.84	250	9.72	246.8	11.59	294.4	17.29	439.1	156,200	70,851	2000	13.8
14-1/4	11.81	300	11.69	296.8	13.91	353.2	18.37	466.7	234,400	106,322	2000	13.8

2250 Internal Pressure Rating

2250 psi (15.5 MPa)

THREAD SIZE	Pipe Inside Diameter		Drift Diameter		Outside Diameter		Coupler Outside Diameter		Tensile Rating		Collapse Pressure Rating	
	in.	in.	mm	in.	mm	in.	mm	in.	mm	lbf	kgs	psi
2-3/8	1.97	50.1	1.85	46.9	2.41	61.1	3.06	77.8	10,700	4,853	2800	19.3
2-7/8	2.46	62.6	2.34	59.4	2.99	76.0	3.65	92.6	14,900	6,759	2800	19.3
3-1/2	3.00	76.1	2.87	72.9	3.63	92.1	4.56	115.9	20,100	9,117	2800	19.3
4	3.15	80	3.02	76.8	3.81	96.8	5.51	140.0	25,100	11,385	2800	19.3
4	3.33	84.6	3.20	81.4	4.03	102.4	5.33	135.4	25,100	11,385	2800	19.3
5-1/4	3.94	100	3.81	96.8	4.76	120.8	6.45	163.8	49,300	22,362	2800	19.3
5-1/2	4.42	112.3	4.30	109.1	5.33	135.5	6.61	167.8	35,000	15,876	2800	19.3
7	5.43	137.8	5.30	134.6	6.54	166.0	9.25	235.0	84,300	38,238	2800	19.3
7-5/8	5.91	150	5.78	146.8	7.12	180.8	9.65	245.2	86,200	39,100	2800	19.3
7-5/8	6.20	157.6	6.08	154.4	7.47	189.8	9.67	245.7	86,200	39,100	2800	19.3
9-5/8	7.87	200	7.75	196.8	9.47	240.6	12.41	315.3	121,900	55,293	2800	19.3
11-1/2	8.86	225	8.73	221.8	10.65	270.6	16.20	411.4	159,500	72,348	2800	19.3
12-1/2	9.84	250	9.72	246.8	11.83	300.6	18.31	465.0	156,200	70,851	2800	19.3
14-1/4	11.81	300	11.69	296.8	14.19	360.4	18.96	481.6	234,400	106,322	2800	19.3

2500 Internal Pressure Rating

2500 psi (17.2 MPa)

THREAD SIZE	Pipe Inside Diameter		Drift Diameter		Outside Diameter		Coupler Outside Diameter		Tensile Rating		Collapse Pressure Rating	
	in.	in.	mm	in.	mm	in.	mm	in.	mm	lbf	kgs	psi
2-3/8	1.97	50.1	1.85	46.9	2.45	62.3	3.05	77.5	10,700	4,853	3100	21.4
3-1/2	2.46	62.6	2.34	59.4	3.06	77.6	6.00	152.3	20,100	9,117	3100	21.4
4	3.00	76.1	2.87	72.9	3.70	94.1	5.60	142.3	25,100	11,385	3100	21.4
4	3.15	80	3.02	76.8	3.89	98.8	5.56	141.3	25,100	11,385	3100	21.4
4	3.33	84.6	3.20	81.4	4.11	104.4	5.51	139.9	25,100	11,385	3100	21.4
5-1/4	3.94	100	3.81	96.8	4.85	123.2	6.63	168.5	49,300	22,362	3100	21.4
5-1/2	4.42	112.3	4.30	109.1	5.44	138.3	6.77	171.9	35,000	15,876	3100	21.4
7	5.43	137.8	5.30	134.6	6.68	169.6	9.66	245.3	84,300	38,238	3100	21.4
7-5/8	5.91	150	5.78	146.8	7.26	184.4	10.13	257.3	86,200	39,100	3100	21.4
7-5/8	6.20	157.6	6.08	154.4	7.63	193.8	10.02	254.6	86,200	39,100	3100	21.4
10	7.87	200	7.75	196.8	9.67	245.6	14.23	361.4	134,700	61,099	3100	21.4

2750 Internal Pressure Rating

2750 psi (19.0 MPa)

THREAD SIZE	Pipe Inside Diameter		Drift Diameter		Outside Diameter		Coupler Outside Diameter		Tensile Rating		Collapse Pressure Rating	
	in.	in.	mm	in.	mm	in.	mm	in.	mm	lbf	kgs	psi
2-3/8	1.97	50.1	1.85	46.9	2.50	63.5	3.07	78.0	10,700	4,853	3400	23.4
3-1/2	2.46	62.6	2.34	59.4	3.12	79.2	5.94	150.9	20,100	9,117	3400	23.4
4	3.00	76.1	2.87	72.9	3.78	96.1	5.84	148.4	25,100	11,385	3400	23.4
4	3.15	80	3.02	76.8	3.97	100.8	5.79	147.0	25,100	11,385	3400	23.4
4-1/2	3.33	84.6	3.20	81.4	4.20	106.6	6.90	175.2	29,300	13,290	3400	23.4
5-1/4	3.94	100	3.81	96.8	4.95	125.8	6.85	173.9	49,300	22,362	3400	23.4
6-5/8	4.42	112.3	4.30	109.1	5.56	141.3	10.45	265.4	52,700	23,904	3400	23.4

3000 Internal Pressure Rating

3000 psi (20.7 MPa)

THREAD SIZE	Pipe Inside Diameter		Drift Diameter		Outside Diameter		Coupler Outside Diameter		Tensile Rating		Collapse Pressure Rating	
	in.	in.	mm	in.	mm	in.	mm	in.	mm	lbf	kgs	psi
2-3/8	1.97	50.1	1.85	46.9	2.56	64.9	3.15	80.0	10,700	4,853	3750	25.9
3-1/2	2.46	62.6	2.34	59.4	3.18	80.8	5.91	150.0	20,100	9,117	3750	25.9
4	3.00	76.1	2.87	72.9	3.86	98.1	6.14	155.9	25,100	11,385	3750	25.9
4	3.15	80	3.02	76.8	4.06	103.0	6.07	154.1	25,100	11,385	3750	25.9
4-1/2	3.33	84.6	3.20	81.4	4.28	108.8	7.36	187.0	29,300	13,290	3750	25.9

DOC. FSMN-CDIG-LDP/AG